

# **RR DELUXE/QL/PL**

REMOTE RELEASE BIRD LAUNCHER

## **Owner's Manual**

Please read this manual thoroughly  
before operating the RR DELUXE, QL, and PL.

# IMPORTANT SAFETY AND PRODUCT INFORMATION

## **WARNING**

**Please read all safety and product information below before using your Dogtra product. Failure to follow these safety instructions could result in injury to you, your dog and others, or it could result in damage to your Dogtra product or other property.**

## **PRODUCT SAFETY**

### **Training Methods**

Dogtra products may be used with a variety of training methods. However, each dog may have a different reaction to training methods and to Dogtra products. Closely observe your dog when determining the right training method to use with your Dogtra product.

### **Aggressive Dogs**

Do not use Dogtra products with aggressive dogs as such dogs may react adversely and cause injury to people or other dogs. Seek the assistance of a dog-training specialist or veterinarian when dealing with aggressive dogs.

### **Children**

Dogtra products are not toys. Adult supervision and close attention are necessary when Dogtra products are used by or near children.

## **PRODUCT DAMAGE**

### **Electrical Product**

Your Dogtra product contains electrical components and batteries. Do not use or keep your product near heat or flammable sources. Such use or storage may damage your

product and/or cause fire, explosion, injury, or property damage.

### **Medical Device Interference**

Dogtra products contain electrical and magnetic components that emit low level electromagnetic waves and radio frequencies. These electromagnetic waves or radio frequencies may interfere with pacemakers, defibrillators, or other medical devices. Consult your physician or medical device maker before using your medical device with a Dogtra product. If you think that your Dogtra product is interfering with your pacemaker, defibrillator, or other medical device, stop using the Dogtra product.

### **Inadvertent Activation**

The digital microprocessor offers thousands of unique codes to eliminate frequency match-up with other Dogtra e-collars. The Constant button will automatically shut down after being held down for 12 seconds or more as a safety feature.

### **UNAUTHORIZED USE**

Your Dogtra product should be used only in a humane manner to train and educate your dog. Dogtra products are not intended for use in any other manner nor are they intended for use with other animals or with humans.

### **BATTERY**

Your Dogtra product contains batteries. Take care when removing and installing batteries as your fingers may get caught. Dispose of batteries as provided by your local regulations. Do not disassemble, crush, heat, or otherwise alter the battery as it may cause fire, injury or property damage.

# CONTENTS

AT A GLANCE .....	5
MAIN FEATURES .....	6
IMPORTANT PRODUCT INFORMATION .....	7
DESCRIPTION OF TRANSMITTER PARTS .....	8
DESCRIPTION OF RECEIVER PARTS .....	10
DESCRIPTION OF LAUNCHER PARTS (QL, PL) .....	12
QL, PL ASSEMBLY AND OPERATION .....	15
QL, PL SPRING STRENGTH SETTINGS .....	22
CHARGING THE BATTERY .....	24
MAXIMIZING THE DISTANCE .....	26
ACCESSORIES .....	27
MAINTENANCE .....	28
WARRANTY AND REPAIR INFORMATION .....	29

# AT A GLANCE

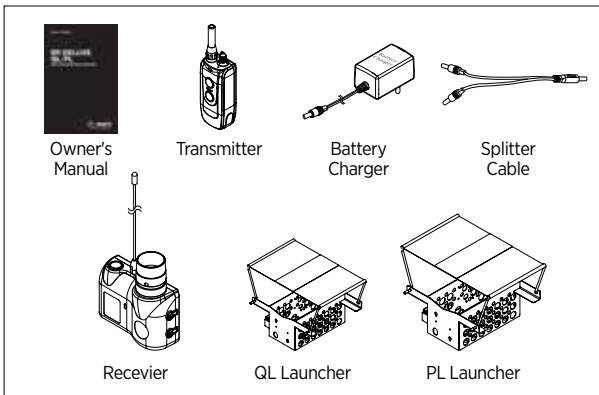

**\*RR DELUXE, QL and PL are sold separately**

## **Optional accessories**

### **Auto Charger**

The auto charger for the RR DELUXE has an input of 12-volts to 24-volts and has an output of 12-volts 300mAH.

### **European Charger**

Dogtra's European chargers are designed for use with a 220 volt AC electrical outlet.

To purchase accessories, please visit [www.dogtra.com](http://www.dogtra.com) or call customer service at (888) 811-9111.

## MAIN FEATURES

- Multiple receivers: one transmitter can control up to 8 receivers which can control up to 16 launcher baskets
- Multiple sound modes: the receiver emits a duck call and beep sound
- Range: effective within one mile
- Scenting: launcher basket and bird cradle are designed for maximum air flow
- Quiet launch: prevents dogs from being startled by a loud release noise
- Waterproof: the handheld transmitter is fully waterproof (receiver is water resistant)
- Multi-colored LED: 3 types of LED colors show the remaining battery life

# IMPORTANT PRODUCT INFORMATION

- DO NOT use the bird launcher until you have read this manual.
- Transport the launcher in a safe position. It should either have the bird cradle open or if it is closed, the safety pin must be inserted to lock the release latch.
- To store for long periods of time, place the bird launcher in the open position to prevent the springs from weakening.
- To avoid danger, keep the bird launcher away from children. Never leave a set bird launcher unattended as the bird cradle can pop open with significant force.
- Do not look down or into it during the launch process because you may be injured as the bird cradle opens up.

## **WARNING!**

Use caution when using a bird launcher. Keep your head away from the top of the launcher when it is loaded. You can be injured if the dummy or bird is accidentally launched.

# DESCRIPTION OF TRANSMITTER PARTS

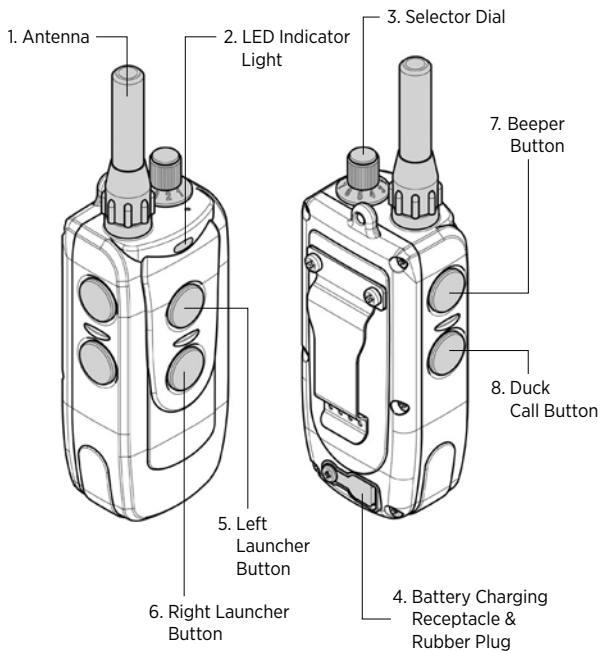

## RR DELUXE Transmitter



- 1. Antenna:** A 2 inch antenna is supplied with the Dogtra RR DELUXE transmitter. The antenna must be fastened to the transmitter before using the unit.
- 2. LED Indicator Light:** The color of the light indicates the status of battery life. Green = full charge; amber = medium charge; red = needs charge. The LED indicator light will come on when the buttons are pressed as well.
- 3. Selector Dial:** By turning the Selector Dial, you can control the desired receivers (one to eight).
- 4. Battery Charging Receptacle & Rubber Plug:** Plug the charger cable jack into this receptacle when charging the transmitter. After charging, make sure the rubber plug is in place so that dirt does not enter the receptacle.
- 5. Left Launcher Button:** Left launcher button releases the launcher connected to the left jack of the receiver.
- 6. Right Launcher Button:** Right launcher button releases the launcher connected to the right jack of the receiver.
- 7. Beeper Button:** Beeper button activates the speaker horn on the receiver to emit a loud beep sound.
- 8. Duck Call Button:** Duck Call button activates the speaker horn on the receiver to emit a series of quacks.

# DESCRIPTION OF RECEIVER PARTS

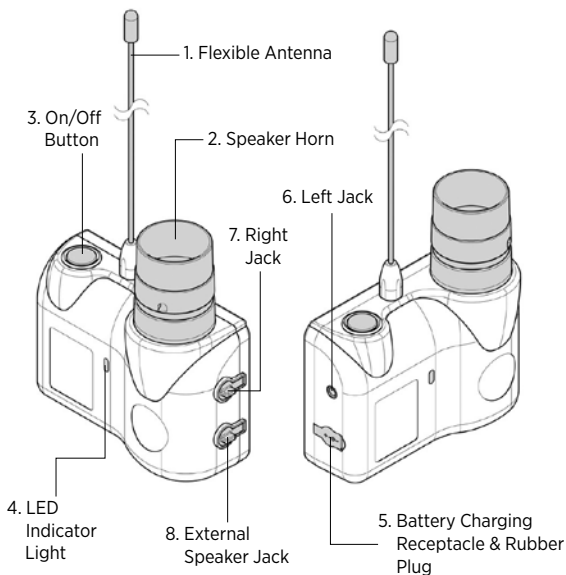

## RR DELUXE Receiver

- 1. Flexible Antenna:** Flexible antenna is located on the top of the receiver. Please do not bend the antenna forcibly since it may cause reduction in the range.
- 2. Speaker Horn:** Sound horn emits loud beep tone or quacking sound when you press Beeper or Duck Call button.
- 3. On/Off Button:** Press the on/off button to turn the power on and off.
- 4. LED Indicator Light:** The color of the light indicates the status of battery life. Green = full charge; amber = medium charge; red = needs charge. The LED indicator light will come on when the transmitter buttons are pressed as well.
- 5. Battery Charging Receptacle & Rubber Plug:** Plug the charger cable jack into this receptacle when charging the receiver. After charging, make sure the rubber cover is in place so that dirt does not enter the receptacle.
- 6. Left Jack:** Jack located on the left side where a launcher can be plugged.
- 7. Right Jack:** Jack located on the right side where a launcher can be plugged.
- 8. External Speaker Jack:** Jack for an external loud speaker, which can be purchased separately.

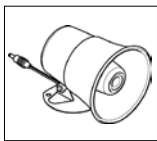

\*External Loud Speaker (Option)

# DESCRIPTION OF LAUNCHER PARTS (QL, PL)

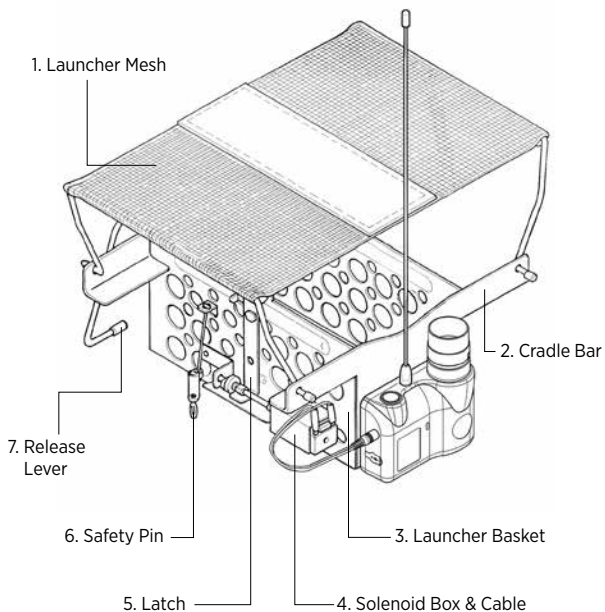

**QL, PL**  
**Launcher Parts**

## **Launcher size**

### **Dogtra QL Launcher**

- 8.6" × 4.5" × 4.3"

- Designed for quail or barn pigeon sized birds.

### **Dogtra PL Launcher**

- 13.2" × 6.9" × 6.9"

- Designed for pheasant and chukar sized game birds.

- 1. Launcher Mesh:** The launcher mesh holds a dummy or bird for launching.
- 2. Cradle Bar:** The cradle bar supports the arms and levers of the basket.
- 3. Launcher Basket:** The launcher basket contains large holes for maximum air flow and scent distribution.
- 4. Solenoid Box & Cable:** The solenoid box & cable activates the launcher by pulling the latch when the launcher button is pressed.
- 5. Latch:** The latch holds the bird cradle closed when it is set for launching.
- 6. Safety Pin:** Insert the safety pin in the hole of the latch to prevent the bird launcher from accidentally launching.
- 7. Release Lever:** The release lever holds the launcher arms and mesh closed.

# QL/PL ASSEMBLY AND OPERATION

## ASSEMBLY

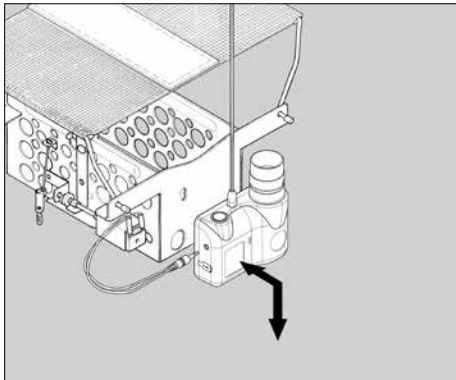

Figure 1. Mounting the receiver

- 1) To mount the receiver, attach the receiver to the launcher box and push down gently so that it locks in place. Check to see whether the receiver is attached securely by gently pulling on the receiver.

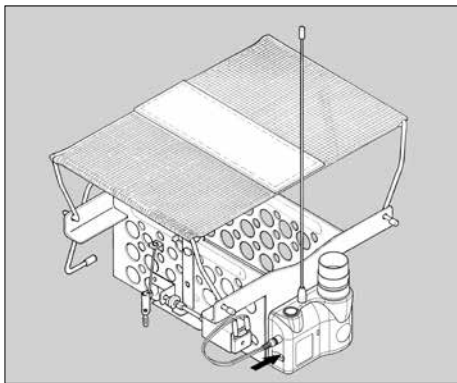

Figure 2. Plugging solenoid cable into the receiver

2) Plug the solenoid cable into the receiver's left jack.



## ASSEMBLY FOR TWO LAUNCHERS

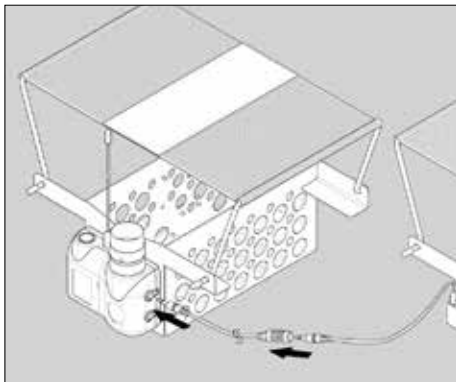

Figure 3. Assembling two launchers on one receiver

- 1) Mount the receiver to the launcher.
- 2) Plug the solenoid cable into the receiver's right jack.

**The other receiver will be plugged into the receiver's left jack. A 15-foot extension cable can be purchased separately.**

## How to launch the Dogtra Remote Release Bird Launchers

- First, test the launcher without any dummy or bird inside.

### **WARNING!**

Keep your head away from the top of the launcher when it is loaded. You could be injured if the dummy or bird is launched accidentally.

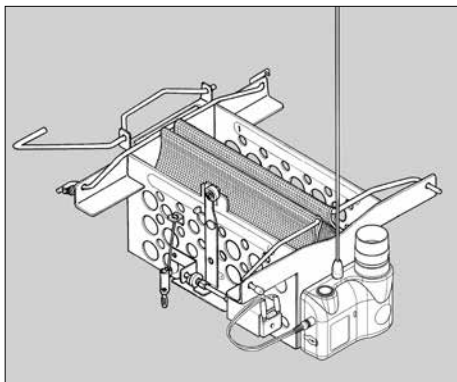

Figure 4. Closing the launcher

- 1) Close the launcher mesh inside of the launcher basket and hold it in place with the release lever.

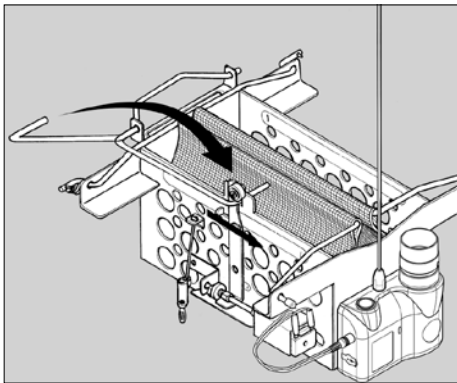

Figure 5. Setting the latch

- 2) Place the release lever under the latch roller bearing.
- 3) Turn the receiver on and make sure that the safety pin has been pulled out.

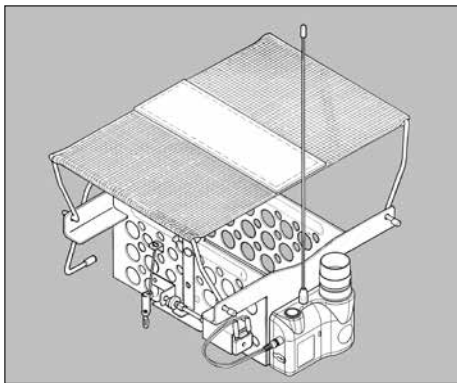

Figure 6. Remote launcher released

- 4) Press the transmitter's left or right launcher button depending on which jack (left or right) it's connected to. The remote launcher is working properly if the bird cradle pops open like the diagram above.
- 5) Press the transmitter's Beeper button or Duck Call button. You'll know it's working properly if the receiver sound horn emits a loud beep or quacking sound.

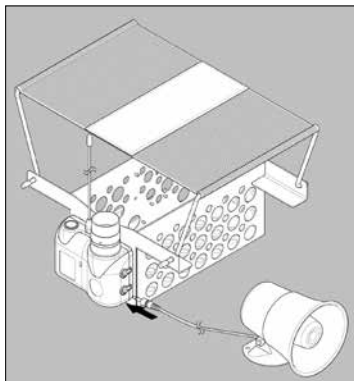

Figure 7. Using the external speaker (optional)

- 6) Plug the external speaker cable to the external speaker jack located on the bottom right side of a receiver. The external speaker cable can be purchased separately.
- 7) Press the transmitter's Beeper button or Duck Call button. The external speaker should emit a loud beep or quack sound.

## QL/PL SPRING STRENGTH SETTINGS

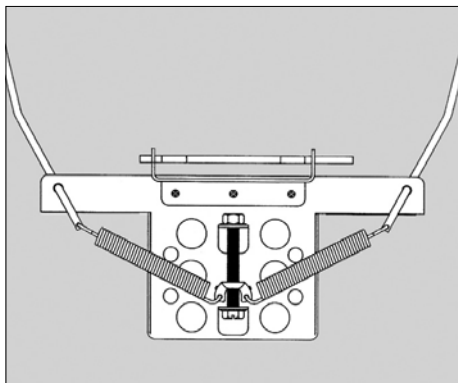

Figure 8. Positioned for high launch

- 1) The bird launcher is shipped with the springs adjusted in the bottom setting. This setting gives you the high launch. Turning clockwise will move the springs down for a higher launch; the very bottom being the highest.

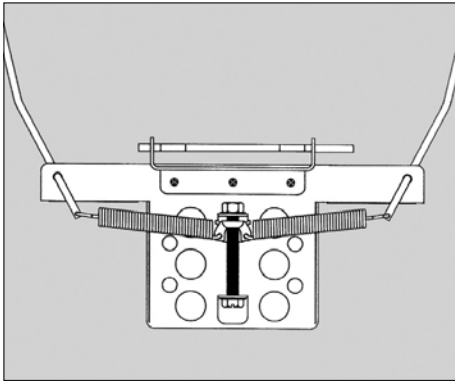
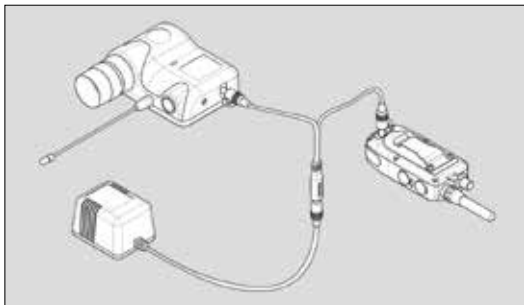

Figure 9. Positioned for low launch

- 2) Turning counter-clockwise will move the springs up for a low and quiet launch; the very top being the lowest.

## CHARGING THE BATTERY



The Dogtra RR DELUXE uses a nickel metal hydride battery. Recharge the unit if the indicator light is red, the light does not come on, or the system will not stay on when any button is pressed.

**NOTE 1:** Only use Dogtra-approved batteries, chargers, and accessories for your Dogtra systems. This will prevent any damage that can be incurred from attempting to use a different charger.

**NOTE 2:** The unit has a partial charge when it leaves the Dogtra facility. Upon receipt of the system, be sure to give it a full 14-hour initial charge before the first use away from any flammable substances.

**NOTE 3:** When a charger is not in use, disconnect it from the power source. Fully charge the batteries if the unit is to be stored without use for a period of 3 months or more.



**Follow the steps below to charge your system:**

1. Open the rubber plugs on the battery charging receptacles and plug in the charging cable.
2. Plug the charger into a 120-volt wall outlet or, if using the auto charger, plug into a cigarette lighter only for lithium polymer batteries (use a 220 volt European charger for Europe). All indicator lights should glow red when properly plugged in and the unit will automatically shut off during the charging process. You will need to turn the unit on again before use once the unit is fully charged and unplugged from the battery cable.
3. The nickel metal hydride battery is fully charged within 14 hours. The lights will stay red when charging and when fully charged. Since that is the case, make sure to note when the 14 hour charging period is complete.
4. After charging, cover the battery charging receptacles with the rubber plugs.

## MAXIMIZING THE DISTANCE

The Dogtra RR DELUXE has a range of 1 mile. Depending on the way you use your transmitter, the transmitter range may vary.

To get the greatest range, hold the transmitter away from your body and avoid touching the antenna. Keep your unit properly charged for maximum signal strength.

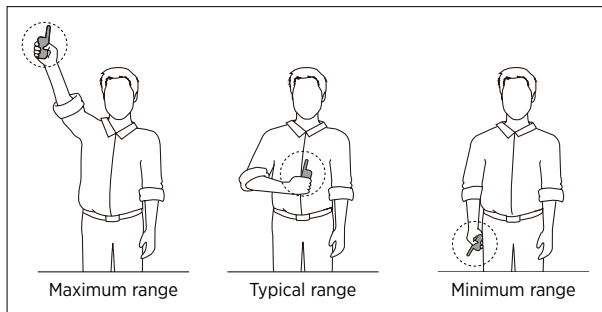

## **ACCESSORIES**

The following items may be purchased separately by calling our customer service at (888) 811-9111 or go to [www.dogtra.com](http://www.dogtra.com).

### **Extension Cable**

A 15-foot cable allows longer distances between the receiver and the launcher.

### **External Loud Speaker**

Attaches to the receiver and gives you increased sound (cord is 4.5-ft long).

### **Auto Charger**

The auto charger for the RR DELUXE has an input of 12-volts to 24-volts and has an output of 12-volts 300mAH.

### **European Charger**

Designed for use with 220 volt AC electrical outlets in Europe.

# MAINTENANCE

## **Basic Maintenance**

Make sure the rubber charging cap is securely in place. After each training session, carefully inspect the unit for any missing parts or damage to the casing. Damaged or broken casing may affect the waterproof guarantee on the unit. After confirming that there is no damage to the casing, rinse the product and clean out any dirt or debris.

## **Storage Maintenance**

The RR DELUXE should be fully charged before storing for extended periods. While in storage, the unit should be given a full charge once a month and before the first use. Store the units in room temperature. Do not keep the units exposed to extreme climates.

## **Troubleshooting**

If the unit is malfunctioning, please refer to the “Troubleshooting Guide” before sending it to Dogtra for service. If you have any questions or concerns, you may email them to [info@dogtra.com](mailto:info@dogtra.com), or call customer service at (888) 811-9111.

# DOGTRA PRODUCT WARRANTY

## LIMITED WARRANTY

### For Dogtra Products Purchased from Dogtra Authorized Dealers

#### One-Year Warranty

Except as otherwise provided below, Dogtra warrants to the original retail purchaser (“You”) that its Dogtra products shall be free of defects in materials and workmanship for a period of one (1) year from the date of purchase (“Warranty”). The Warranty covers the cost of repair (parts and labor) or replacement (if repair is not feasible) of a defective Dogtra product during said one-year period. For such repaired or replaced products, the remaining portion of the original warranty period, or ninety (90) days, whichever is longer, shall apply. Dogtra, at its sole discretion, shall determine whether to repair or replace a product covered by the Warranty.

#### Warranty Conditions

The Warranty is not transferrable and applies to your Dogtra product only if:

- (1) You are the original retail purchaser of the product,
- (2) You bought the product from a Dogtra authorized dealer, and
- (3) You present a receipt or other proof of purchase showing a valid purchase date, the name and address of the authorized dealer, and the purchased product identified by model and/or serial number.

#### Warranty Exclusions

The Warranty does not cover damage, loss, or deterioration to your Dogtra product caused: by misuse, neglect, abuse, or other improper handling of the product; by failure to follow use or care instructions; by use of the product for other than its intended purpose; by accident or natural forces such as fire or flooding; or by normal wear and tear such as scratches to the product surface.

The Warranty also does not cover Dogtra products that: are purchased from non-authorized dealers; are purchased outside of the United States or Canada; have been damaged during shipment (even if Dogtra paid or arranged for shipping); have been modified or tampered with in any manner; are opened or repaired by anyone other than Dogtra; or have serial numbers that have been altered or defaced.

#### Sole Warranty

This Warranty is the only warranty offered by Dogtra for its Dogtra products. Other than said Warranty, Dogtra makes no other representations or warranties whatsoever regarding its products, whether oral or in any product manual, on any packaging, on any website, or in any other written material. No dealer of Dogtra products, nor any employee or agent of Dogtra, is authorized to make any additions, changes, or extensions to the Warranty. Dogtra, at its sole discretion and at any time, reserves the right to modify the Warranty.

## **DISCLAIMER OF OTHER WARRANTIES**

**THE FOREGOING WARRANTY IS PROVIDED IN LIEU OF ALL OTHER WARRANTIES, WHETHER EXPRESS OR IMPLIED. DOGTRA DISCLAIMS ANY IMPLIED WARRANTIES INCLUDING, BUT NOT LIMITED TO, THE IMPLIED WARRANTIES OF MERCHANTABILITY AND FITNESS FOR A PARTICULAR PURPOSE.**

### **Limitation of Remedies**

Dogtra's liability is limited to the cost of repair or replacement of the Dogtra product under Warranty. Any claim or action to enforce the Warranty must be commenced within thirty (30) days of the Warranty's expiration for your product. Dogtra will not be liable for any indirect, incidental, special, consequential, or similar damages based on breach of warranty, breach of contract, negligence, strict tort, or any other legal theory related to Dogtra and its products. Damages that Dogtra will not be responsible for include, but are not limited to: loss of income or profits; loss of revenue or savings; loss of use of the product or associated products; cost of any substitute products or services; inconvenience, downtime, or any other time; loss of goodwill; claims of third parties including customers; and damage to property.

### **Legal Rights May Vary By State or Jurisdiction**

The Warranty gives You specific legal rights, and You may also have other rights which vary by state or jurisdiction. Some states or jurisdictions do not allow certain limitations of implied warranties or of incidental or consequential damages or other remedies, so certain of the foregoing limitations may not apply to You.

If any portion of the Warranty is held by a court to be invalid or unenforceable, the remaining portions of the Warranty shall remain in full force and effect and shall in no way be affected or invalidated, and the invalid or unenforceable portion shall be modified so as to most nearly achieve the intent of the Warranty.

### **Product Registration**

Dogtra recommends that customers register their products as soon as possible after purchase. Product registration will facilitate any future warranty service. You may also receive useful information and updates about your existing and future Dogtra products. To register your product, visit [www.dogtra.com/product-registration](http://www.dogtra.com/product-registration). If your product is not registered with Dogtra, You will be required to provide a receipt or other proof purchase (as provided above) to qualify for warranty service.

### **How to Obtain Warranty Service**

Should your Dogtra product require warranty service, please contact Customer Service by phone or email for a warranty evaluation (see below for contact information). Upon approval of your warranty work, Dogtra will repair or replace (at Dogtra's election) your product without charge for labor or parts. You are responsible for shipping, including cost, of your product to Dogtra for warranty service. Dogtra will handle shipping, including cost, of the repaired or replaced product back to customers in the USA. Dogtra will not be responsible for shipping, including cost and/or applicable taxes or fees, for products sent to Canada. Such costs, taxes, or fees will be borne by the customer.

To register your product, visit [www.dogtra.com/product-registration](http://www.dogtra.com/product-registration).

### **Dogtra Customer Service**

**12322 Monarch Street, Garden Grove, CA 92841**

(888) 811-9111

repair@dogtra.com

Mon – Fri, 8:00 AM to 4:30 PM (PST)

© 2021 Dogtra. All rights reserved.