



**Owner's Manual**

**Remote Controlled Dog Training Collars**

***dogtra* 175NCP**



**Dogtra Company**

22912 Lockness Avenue  
Torrance, CA 90501 U.S.A.

Tel) 310.534.0101

Fax) 310.534.9111

Toll Free) 1.888.811.9111

Copyright © 2006 Dogtra Company All rights reserved. (5)

A large, faint, light gray watermark of a dog's head profile is visible in the bottom right corner of the page, partially overlapping the website address.

[www.dogtra.com](http://www.dogtra.com)

- MAIN FEATURES ..... 2
- PRODUCT SAFETY AND HEALTH STATEMENTS ..... 3
- **dogtra** COLLAR PACKAGE CONTENTS ..... 5
- DESCRIPTION OF TRANSMITTER PARTS ..... 6
- DESCRIPTION OF COLLAR / RECEIVER PARTS .... 13
- BATTERY CHARGER ..... 18
- CHARGING THE BATTERIES ..... 19
- TESTING YOUR **dogtra 175NCP** COLLAR.... 22
- OPERATING INSTRUCTIONS ..... 24
- ACCESSORIES ..... 28
- WARRANTY AND REPAIR INFORMATION .... 29

### MAIN FEATURES

- Easy-to-use, ergonomic transmitter.
- Rheostat dial that allows for gradual increases in stimulation intensity with no jumps between levels.
- The **dogtra 175NCP** has a range of 400+ yards.
- Waterproof collar/receiver and water-resistant transmitter.
- No external antenna on the collar receiver.
- Rechargeable, user-replaceable Ni-MH batteries.
- One-charger system allows the transmitter and receiver to be charged at the same time.
- Over 999 different identity codes to prevent conflicts with other e-collars.

### PRODUCT SAFETY AND HEALTH STATEMENTS

#### Safety for your dog

Studies conducted by animal health professionals at Dogtra Company's training facilities showed no adverse effects to the cardiovascular or nervous system of dogs from e-collar stimulation. These studies involved healthy dogs in a controlled environment.

Dogs should be in good health during any e-collar training. Dogtra e-collars are not intended for use on dogs weighing less than 12 pounds or under 6 months of age.

Skin irritation can occur from prolonged wearing of the stainless steel contact points on the training collar. Most dogs will exhibit some type of irritation (pressure necrosis) from prolonged contact of stainless steel contact points. This is why it states in your owner's manual:

#### Attention:

Avoid having the dog wear the collar with the contact points in the same place for more than two hours at a time. Leaving the contact points on the same spot for an extended period of time can cause skin irritation. If the dog is to wear the e-collar for long periods, occasionally reposition the collar so that the contact points are moved to a different spot on the dog's neck.

**Proper e-collar use**

Dogtra e-collars are intended for the sole purpose of behavior modification of dogs. They are not intended for human use or use on other animals. Dogtra Company does not assume any liability for improper use of the Dogtra e-collar.

**Aggressive dogs**

Dogtra does not recommend using the e-collar to correct dogs that are aggressive towards other dogs or people. In many such cases the dog will associate the stimulation with the other dog or individual and become even more aggressive. Dog aggression is best treated by a dog training specialist.

**Interference with other electronic devices**

Dogtra’s industry-leading technology filtering system ensures minimal interference with other electronic devices (cellular phones, security systems, etc.). Our digital microprocessor offers thousands of unique codes to eliminate frequency match-up with other Dogtra e-collars.

**Inadvertent activation**

If the constant button is held down for 12 seconds or more the unit will automatically shut down. It will reactivate when the button is released.

***dogtra* COLLAR  
PACKAGE CONTENTS**

- Transmitter
- Receiver
- Battery charger and splitter cable
- Owner’s manual

## DESCRIPTION OF TRANSMITTER PARTS

*dogtra* 175NCP transmitter

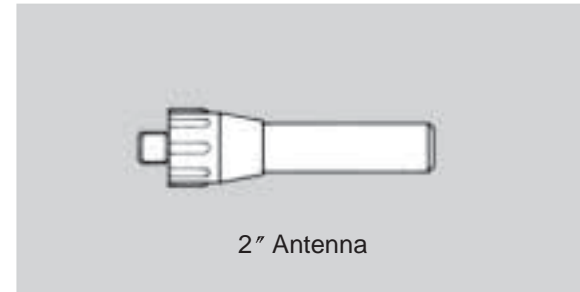
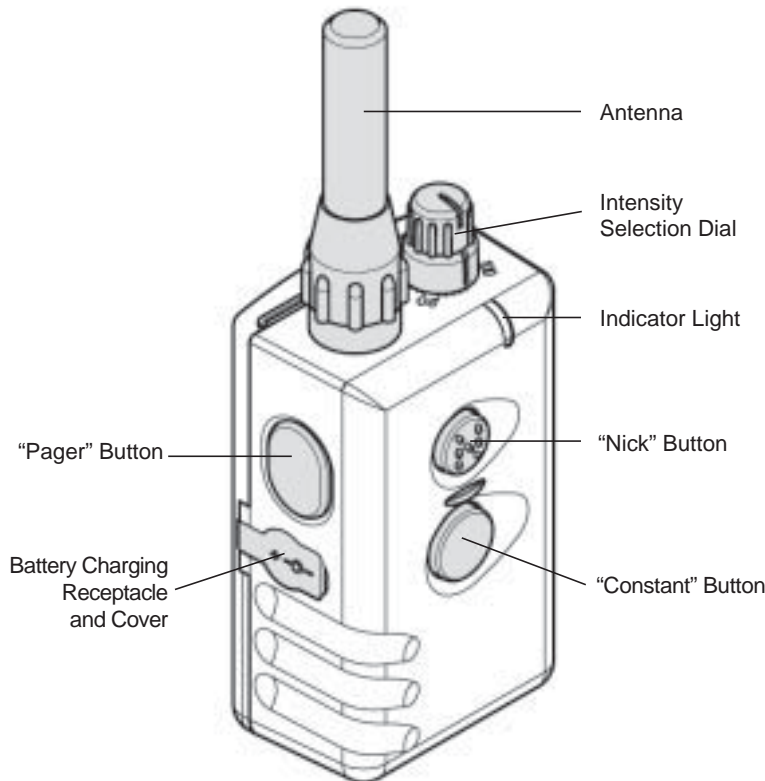

### Transmitter Antenna

A short 2" antenna is supplied with the *dogtra* 175NCP transmitter.

The antenna should be screwed into the top of the transmitter to ensure that the signals are sent properly to the collar receiver and that maximum range is attained.

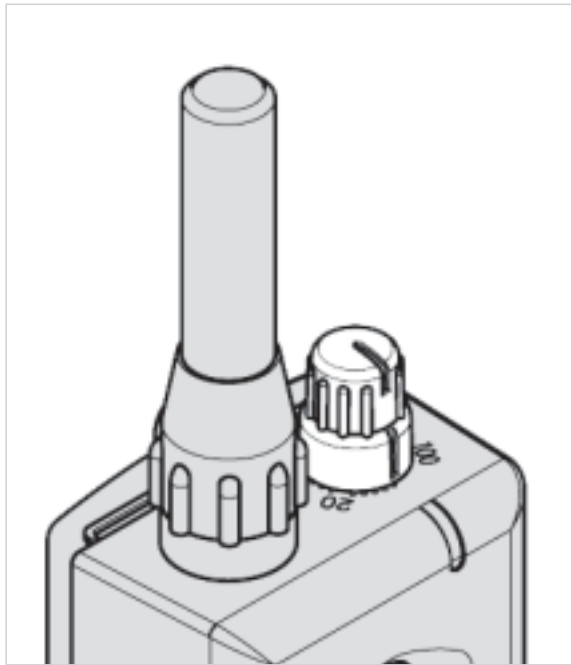

### Intensity Selection Dial

The intensity selection dial is located on the top of the transmitter: (0) being the lowest level and (100) being the highest.

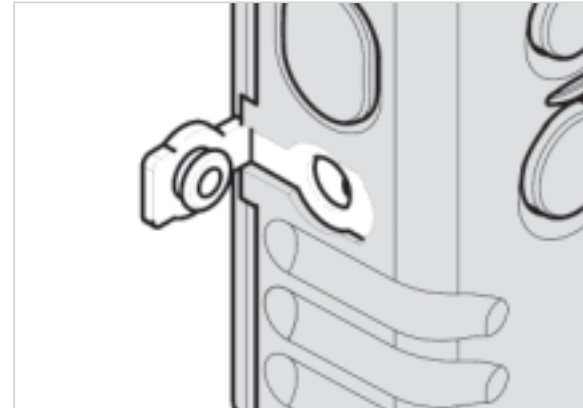

### Transmitter Battery Charging Receptacle

Located on the side of the transmitter, the receptacle is covered by a rubber plug. Insert one end of the battery charging cable into the receptacle to charge the battery. (See Battery Charging Procedure on page 21.)

After charging is completed, cover the receptacle with its rubber plug to make sure dirt or water does not get inside.

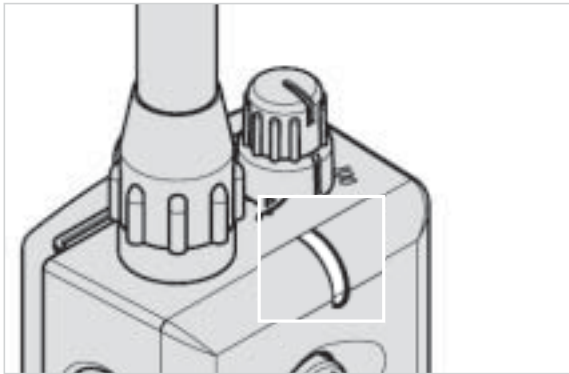

**Transmitter Indicator Light (LED window)**

The transmitter indicator light is located near the intensity selection dial. When a button on the transmitter is pushed, the light comes on to indicate that the transmitter is being activated. The color of the light indicates the status of battery life. The LED glows green when the battery is fully charged and turns to amber when battery life is getting low. When the LED emits a blinking red light, the battery needs to be recharged.

**green** = full charge, **amber** = medium charge  
**red** = needs charge

**BUTTON FUNCTION**

***dogtra 175 NCP***

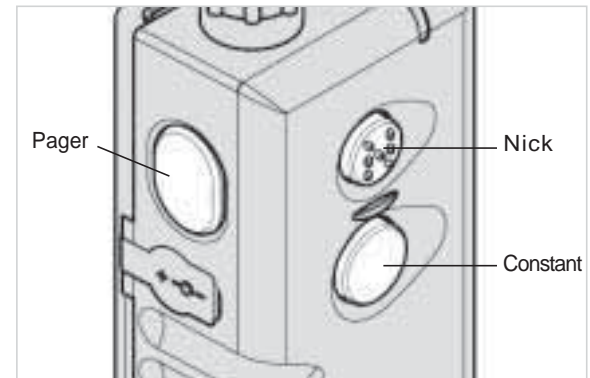

The transmitter for ***dogtra 175 NCP*** has three buttons (two on the face of the transmitter and one on the side).

**“Nick” Button**

When the “Nick” button is pushed the receiver emits a single, rapid pulse of electrical stimulation.

**“Constant” Button**

Pressing the “Constant” button gives continuous stimulation as long as the button is pushed, for up to twelve seconds. If the button is not released after twelve seconds, the stimulation will automatically turn off as a safety feature. The collar will be ready to be reactivated once the button has been released.

**“Pager” Button**

Pressing the “Pager” button on the side of the transmitter causes the collar to vibrate. This is a great way of communicating with your dog using non-electrical stimulation.

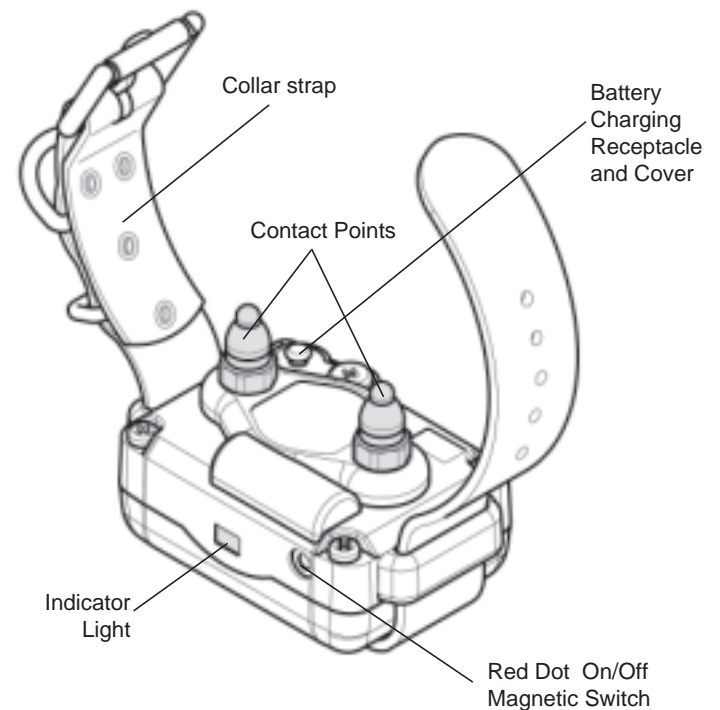
**DESCRIPTION OF  
COLLAR / RECEIVER PARTS*****dogtra* 175NCP Collar**



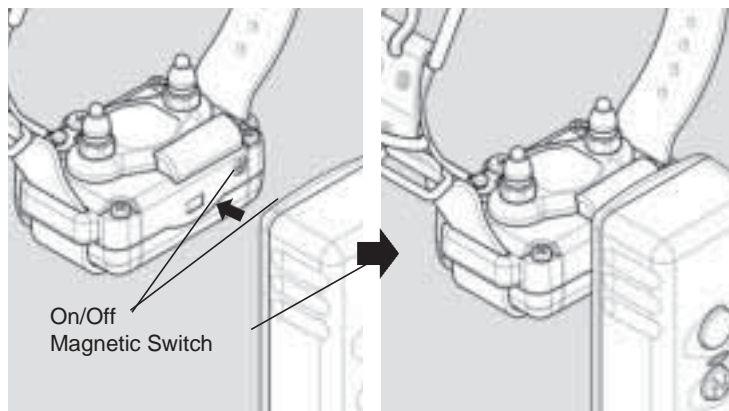

### On/Off Magnetic Switch

To activate the **dogtra 175NCP**, place the red dot on the back of the transmitter to the red dot on the collar receiver. Hold the two red dots together for a moment until the LED indicator light comes on.

To deactivate the **dogtra 175NCP** repeat the same procedure holding the two red dots together momentarily. The LED light will stop blinking, indicating that the unit is now shut off. To attain maximum battery life, deactivate the unit when not in use.

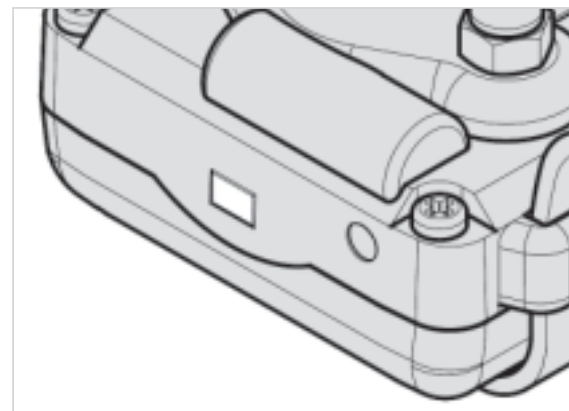

### Receiver Indicator Light (LED window)

Located on the front of the collar, the indicator light comes on and blinks once every 2 seconds after the collar is turned on. The color of the LED indicates the battery life of the receiver. (**green** = full charge, **amber** = medium charge, **red** = needs charge)

When the “Constant” button on the transmitter is pushed, the collar indicator light will glow steadily as long as you hold the button down, for up to twelve seconds. When the “Nick” button is pushed, the light comes on for a fraction of a second.

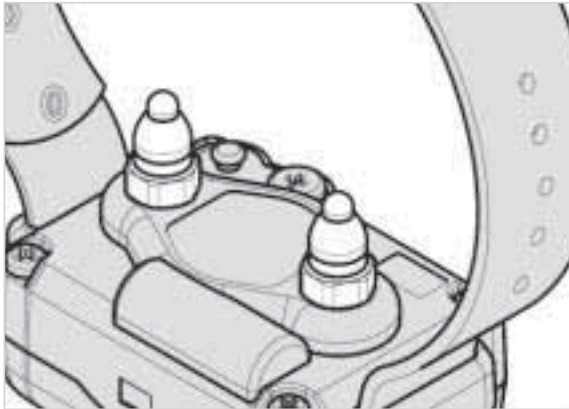

### Fitting the Collar on the Dog

The collar should be fitted so that the stainless steel contact points press firmly against the dog's skin.

A loose fit can allow the collar to move around on the dog's neck. When this happens the contact points may rub the skin and cause irritation. If the collar is too loose, electrical contact will be inconsistent and your corrections will be inconsistent also.

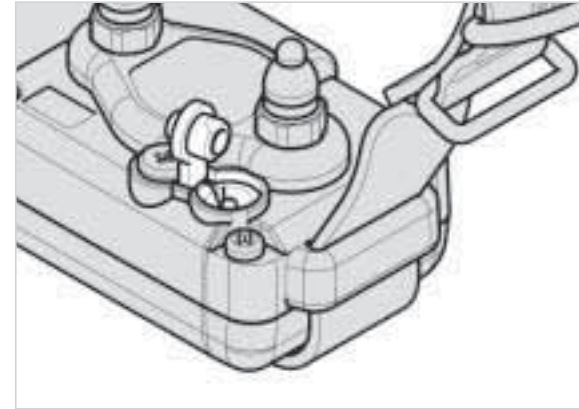

### Receiver Battery Charging Receptacle

On the inside of the collar, next to the collar strap, is a battery charging receptacle with a rubber cover plug.

### Internal Antenna

The **dogtra 175 NCP** has a non-exposed antenna that is located inside the collar receiver.

### BATTERY CHARGER

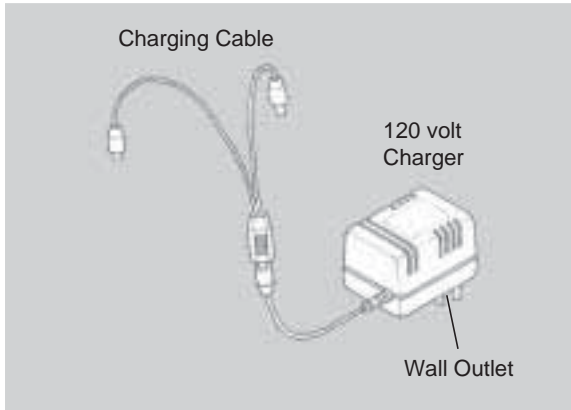

The battery charger and charging cables allow you to charge both the transmitter and receiver at the same time. The battery charger is designed for a 120-volt wall outlet. (European 230-volt AC chargers and 12-volt field charger for your automobile are also available.)

### CHARGING THE BATTERIES

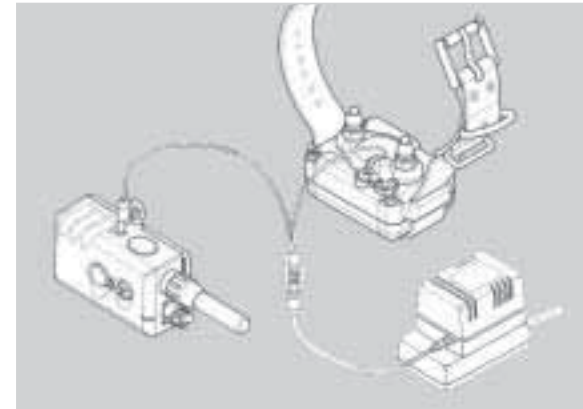

Dogtra uses Ni-MH (Nickel-Metal-Hydride) batteries that do not set a memory and can be charged on a regular basis without harm to the battery. There is no need to completely drain the batteries between charges. However, doing so will help to extend the overall lifetime of the batteries.

1. Charge the batteries for 10 hours before using the collar for the first time.

2. Do not charge the batteries near any flammable substances.
3. Fully charge the batteries for 10 hours if the unit is to be stored without use for a period of a month or more.
4. Recharge the unit if:
  - the indicator light on the collar is emitting a red color
  - the indicator light on the transmitter or receiver will not come on
  - the indicator light on the transmitter or receiver comes on momentarily, but will not stay on when the “Constant” button is pushed.

### Battery Charging Procedure

1. Attach the charging cables to both the transmitter and receiver(s), as shown on page 19.
2. Plug the charger into a 120-volt wall outlet or, if using the accessory field charger, plug into a cigarette lighter. (Use a 230-volt European charger for Europe.) When properly plugged in, all indicator lights should glow red.

The receiver automatically turns off when you insert the charging cable into the battery-charging receptacle on the receiver.
3. After charging, cover the battery charging receptacles with the rubber plugs on the transmitter and receiver.
4. The battery is fully charged with a 10-hour charge. The lights will stay red during the charging process. They DO NOT turn green when fully charged. Charging the batteries for more than 10 hours at one time will not extend battery life.

## TESTING YOUR *dogtra* 175 NCP COLLAR

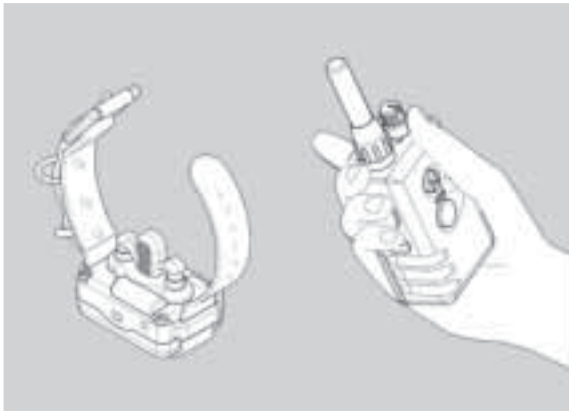

1. To activate the *dogtra* 175 NCP, place the red dot on the back of the transmitter to the red dot on the collar. Hold the two red dots together for a moment until the LED indicator light comes on. The indicator light will blink every two seconds showing the unit is charged and ready to use. (If the indicator light emits a red color, the batteries need to be charged.)

2. Turn the intensity level on the transmitter up to the maximum level (100) and press the Nick button. The indicator light(LED) on the collar receiver will light briefly as you push the button. Pressing the Constant button will light the indicator for as long as you hold the button down, up to twelve seconds.
3. As a safety feature, the *dogtra* 175 NCP will automatically shut off stimulation if the constant button is depressed for twelve seconds or longer. The button will be ready to be reactivated once the button is released.

## OPERATING INSTRUCTIONS

### Fitting the Collar

The collar strap should be adjusted so that the contact points are held firmly against the dog's skin. If the collar is too loose, irritation may result from the contact points rubbing against the skin.

If the dog has a heavy coat, move the receiver up and down to work the contact points down into the coat.

### ATTENTION!

**Avoid having the dog wear the collar with the contact points in the same place for more than two hours at a time. Leaving the points on the same spot for extended periods of time can cause skin irritation. If the dog is to wear the e-collar for long periods, occasionally reposition the collar so that the contact points are placed in a different spot on the dog's neck.**

### Intensity Selection

To select the intensity level, start on the zero (0) setting. Gradually increase the level until you get a response from the dog that would be equivalent to a quick pull or jerk with a leash.

Remember that you will need to adjust the setting (upward or downward) as the dog's attitude changes, especially during times of increased excitement or distraction.

Prolonged use of the Pager (12 seconds or longer) will drain the batteries more quickly.

## Maintenance

The receiver and collar strap should be cleaned periodically with detergent and water to prevent malfunction.

Always clean and rinse the collar thoroughly with tap water after use in salt water. Be sure the charging receptacle is completely dry before inserting the battery charger into the transmitter or receiver.

## Reception

The **dogtra 175NCP** e-collar has a range of 400+ yards. Depending on the way you use your transmitter, the transmitting range may vary. Hold the transmitter away from your body and avoid touching the antenna to get the greatest range.



Maximum Range



Typical Range



Minimum Range

If your finger touches the antenna near the dial on the top of the transmitter, the actual range may be reduced. Additional environmental factors may also affect the range of your unit.

## ACCESSORIES

The following items may be purchased separately:

### European Charger

Designed for use with 230V AC electrical outlets in Europe.

### Field Auto Charger

Designed for use with the 12-volt cigarette lighter in your car.

## WARRANTY AND REPAIR INFORMATION

**Dogtra Company** provides the original purchaser with a **LIMITED LIFETIME WARRANTY**. Limited Lifetime Warranty begins from the date of purchase. For the first two years, coverage is for both parts and labor, on all our products purchased new. Accessories such as, chargers, splitter cables, antennas, straps and **batteries** have a one-year warranty from the date of purchase. Once the first and second year warranty coverage expires, the Limited Lifetime Warranty will cover for all parts except accessories and labor fees. Labor fees and shipping fees incurred are the customers' responsibility. Labor fees will be variable depending on the extent of work required. The Limited Lifetime Warranty will expire 5 years from the date a model is discontinued in production by Dogtra Company.



**To Qualify for the Limited Lifetime Warranty :**

To register your Dogtra product, please log onto our website at [www.dogtra.com](http://www.dogtra.com), click on the warranty registration link and fill out the required information. All registration must be completed within 30 days of your purchase. If you do not have access to a computer, you can call our toll free number of 888-811-9111 so one of our customer service representatives can register your product online for you. Also if you were unable to register your product on our website we will accept all products for repair with a proof of purchase. We strongly recommend you keep your original receipt. If your product is not registered and proof of purchase is not available at the time of service, Dogtra will estimate the age of the unit by the serial number. Serial number estimates can be different than the actual purchase time. Without proof of purchase or product registration this is the only method we have for determining the approximate date of purchase.

**Not Covered Under Warranty :**

We cannot offer warranty for units/products that have been bought secondhand or as a resold product.

Dogtra **DOES NOT** replace defective units or provide refunds for products purchased from us after 30 days from the date of the purchase. Issues of replacement and refunds on units purchased less than 30 days from an authorized dealer need to be addressed to the dealer directly.

Dogtra's warranty **DOES NOT** cover repairs or replacements due to misuse by the owner or dog, improper maintenance, and/or lost units. Any water damage on the Water Resistant Transmitters of the 175NCP, 180NCP, 200NCP, 202NCP, 1400NCP, 1402NCP, 1500NCP and 1502NCP will also not be covered. All replacement cost for either the transmitter or receiver will be the owner's responsibility.

**\* Battery replacement by the customer during the first year of the warranty is not recommended. If the customer chooses to replace the batteries, any damage to the unit during the change-out by the owner will void the warranty.**

The warranty is void if the unit has been altered or an unauthorized person has attempted repair work.

**Procedure for Repair Work :**

The cost of shipping products under warranty back to Dogtra is the customer's responsibility. Dogtra will provide/pay (via regular ground service, within the continental United States) the shipping cost back to the customer. Any expedited shipping service will be at the customer's expense. Dogtra is not responsible for loss of training time or inconvenience while the unit is in for repair work. **Dogtra does not provide loaner units or any form of compensation during the repair period.**

A copy of the sales receipt showing the purchase date is required before warranty work is initiated.

Please include a brief explanation outlining the problems and include your name, address, city/state/zip code, **daytime phone number, evening phone number, and email address.** Or, you can visit our website at [www.dogtra.com](http://www.dogtra.com). Click on the Service Request Form, print it out and follow the instructions.

**If repair costs are not covered under warranty, we will call you for credit card information once the work has been completed.** For any questions concerning your Dogtra products call us Toll Free at 1-888-811-9111, M-F 8:30AM - 4:00PM, Pacific Time, or email us at [repair@dogtra.com](mailto:repair@dogtra.com) for specific repair inquiries.

Send repair units to:

Dogtra Company / Repairs  
22912 Lockness Avenue  
Torrance, CA 90501  
U.S.A.



