

2700T&B

AVAILABLE IN 2-DOG SYSTEM: 2702T&B

Owner's Manual

Please read this manual thoroughly
before operating the Dogtra 2700T&B or 2702T&B
Training & Beeper e-collar.

IMPORTANT SAFETY AND PRODUCT INFORMATION

WARNING

Please read all safety and product information below before using your Dogtra product. Failure to follow these safety instructions could result in injury to you, your dog and others, or it could result in damage to your Dogtra product or other property.

PRODUCT SAFETY

Training Methods

Dogtra products may be used with a variety of training methods. However, each dog may have a different reaction to training methods and to Dogtra products. Closely observe your dog when determining the right training method to use with your Dogtra product.

Aggressive Dogs

Do not use Dogtra products with aggressive dogs as such dogs may react adversely and cause injury to people or other dogs. Seek the assistance of a dog-training specialist or veterinarian when dealing with aggressive dogs.

Children

Dogtra products are not toys. Adult supervision and close attention are necessary when Dogtra products are used by or near children.

PRODUCT DAMAGE

Electrical Product

Your Dogtra product contains electrical components and batteries. Do not use or keep your product near heat or flammable sources. Such use or storage may damage your

product and/or cause fire, explosion, injury, or property damage.

Medical Device Interference

Dogtra products contain electrical and magnetic components that emit low level electromagnetic waves and radio frequencies. These electromagnetic waves or radio frequencies may interfere with pacemakers, defibrillators, or other medical devices. Consult your physician or medical device maker before using your medical device with a Dogtra product. If you think that your Dogtra product is interfering with your pacemaker, defibrillator, or other medical device, stop using the Dogtra product.

Inadvertent Activation

The digital microprocessor offers thousands of unique codes to eliminate frequency match-up with other Dogtra e-collars. The Constant button will automatically shut down after being held down for 12 seconds or more as a safety feature.

UNAUTHORIZED USE

Your Dogtra product should be used only in a humane manner to train and educate your dog. Dogtra products are not intended for use in any other manner nor are they intended for use with other animals or with humans.

BATTERY

Your Dogtra product contains batteries. Take care when removing and installing batteries as your fingers may get caught. Dispose of batteries as provided by your local regulations. Do not disassemble, crush, heat, or otherwise alter the battery as it may cause fire, injury or property damage.

CONTENTS

AT A GLANCE	5
MAIN FEATURES	6
OVERVIEW	8
UNDERSTANDING YOUR TRAINING SYSTEM	
1. TURNING THE 2700T&B ON/OFF	11
2. TRANSMITTER BUTTON FUNCTION	13
3. BEEPER SOUND	16
4. BEEPER VOLUME ADJUSTMENT	17
5. RECEIVER FITTING	18
6. FINDING THE RIGHT STIMULATION	19
7. FAMILIARIZING THE DOG TO THE BEEPER	20
8. MAXIMIZING THE DISTANCE	20
9. LED INDICATOR	22
10 CHARGING THE BATTERY	23
11. HANDHELD TRANSMITTER LCD	25
12. ATTACHING THE BELT CLIP	27
13. USING THE TEST LIGHT	28
GENERAL TRAINING TIPS	31
MAINTENANCE	33
TROUBLESHOOTING GUIDE	34
WARRANTY AND REPAIR INFORMATION	37

AT A GLANCE

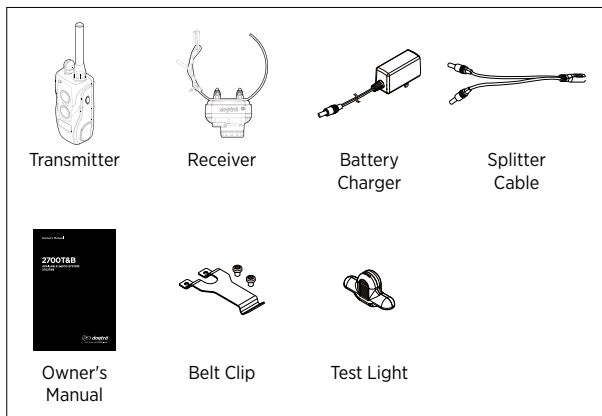

Optional Accessories

Auto Charger

The auto charger for the 2700T&B has an input of 12-volts to 24-volts and has an output of 10-volts 1500mAh.

European Charger

Dogtra's European chargers are designed for use with a 220 volt AC electrical outlet.

To purchase accessories, please visit www.dogtra.com or call customer service at (888) 811-9111.

MAIN FEATURES

- Easy-to-use, ergonomically fitted transmitter
- Rheostat Dial that allows for gradual adjustments in stimulation intensity with no jumps between levels (0-127)
- Two-dog models allow the trainer to control two different dogs from one transmitter
- 1-mile range
- 2 different stimulation types - Nick & Constant
- High Performance Pager (HPP) vibration feature
- Advanced Accelerometer Run/Point sensor
- The freedom to choose between a high and low pitch beeper (single-dog unit only)
- Three beeper modes - Run/Point, Point-Only, and Locate
- Innovative beeper volume control that lets you select between 2 different pitches and 3 volume levels for each pitch
- Combines the receiver with the beeper horn into one small, compact unit
- 2-hour rapid charge lithium polymer batteries
- IPX9K waterproof certified receiver and transmitter
- No bothersome external antenna on the receiver

- One-charging system allows the transmitter and receiver(s) to be charged at the same time
- Easily visible blue LCD screen displays the exact level of stimulation that can be seen in the dark
- A three bar battery life indicator and LED colored indicator to show the remaining battery life

OVERVIEW

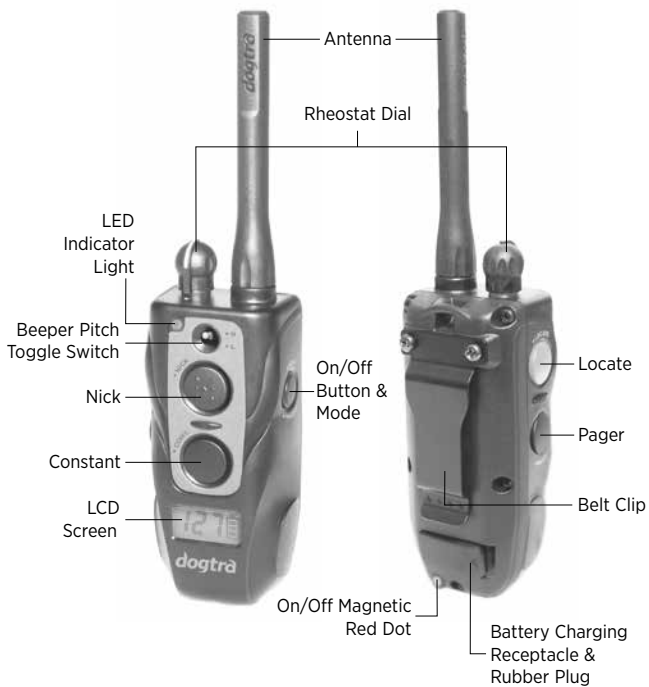

**2700T&B 1-Dog
Transmitter**

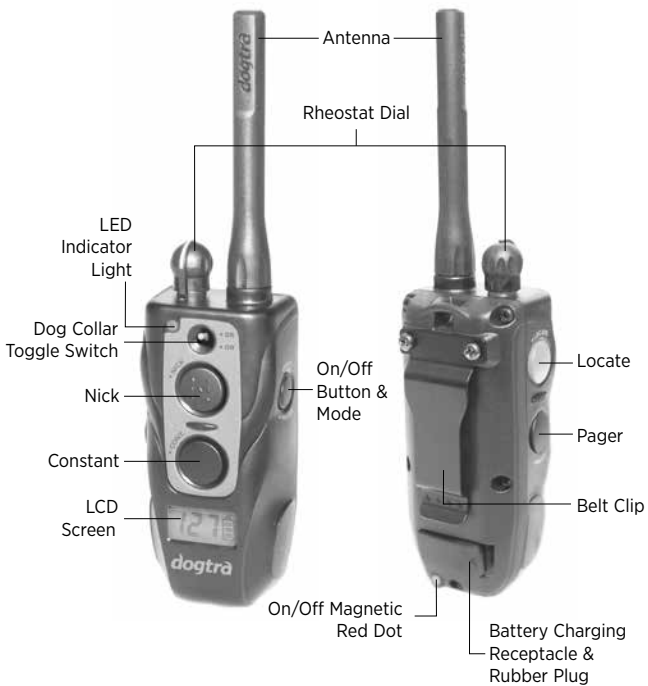

2702T&B 2-Dog Transmitter

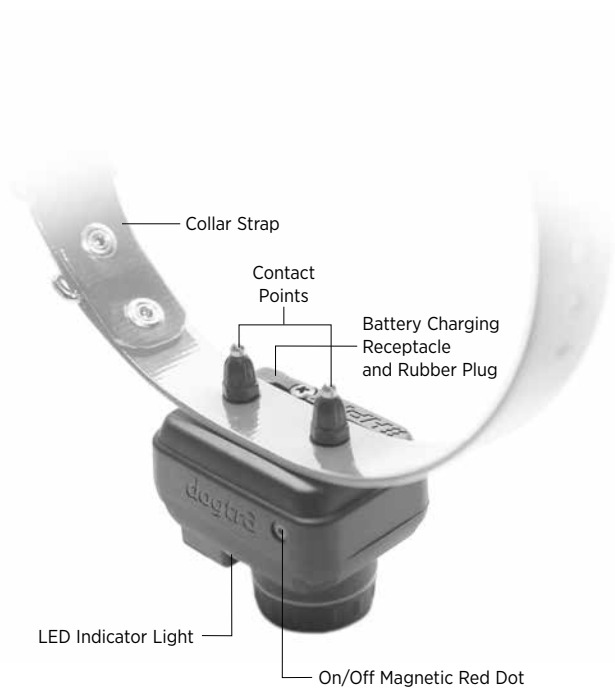

**2700T&B, 2702T&B
Receiver**

UNDERSTANDING YOUR TRAINING SYSTEM

1. Turning the 2700T&B On/Off

To turn the handheld transmitter on, hold down the button on the right side of the transmitter until the LCD screen illuminates. To turn the transmitter off, hold down the same button on the right side of the transmitter until the LCD screen shuts off.

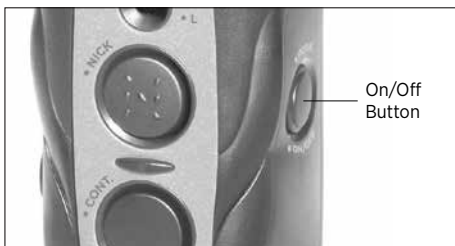

Receiver On/Off Magnetic Red Dot

To turn on the receiver, place the magnetic red dot on the back of the transmitter to the red dot on the receiver. Hold the two red dots together for a moment until the LED light on the receiver comes on. The receiver will emit a melody when turned on.

To turn off the unit, repeat the same procedure holding the two red dots together momentarily. The LED light will turn red for a brief moment indicating that the receiver has now shut off. The receiver will emit a melody when turned off.

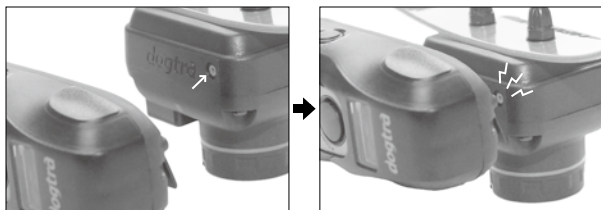

2. Transmitter Button Function

2700T&B



The transmitter for the 2700T&B has five buttons (two on the face of the transmitter, two on the left side, and one on the right side).

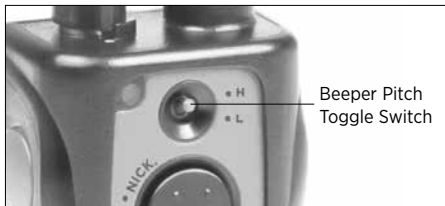

Nick Button

When the Nick button is pressed, the receiver emits a single rapid pulse of electrical stimulation.

Constant Button

Pressing the Constant button gives continuous stimulation as long as the button is pressed, for up to 12 seconds. If the button is not released after 12 seconds, the stimulation will automatically turn off as a safety feature. The receiver will be ready to be reactivated once the button has been released.

Locate Button

The Locate button is located on the left side. It causes the receiver's beeper horn to emit a series of beeps when held down and gives you the ability to keep track of your dog's location. On one-dog models, the beeper can be adjusted between high and low pitches.

Note: The high/low pitch is not an option on two dog units. On two-dog models, the green receiver emits the high pitch and the orange receiver emits the low pitch automatically. The pitch cannot be changed.

Pager Button

The Pager button is located on the left side of the transmitter. Pressing it will give a vibration for as long as the button is pressed, for up to 12 seconds.

Mode Button

Your 2700T&B has three different modes: Locate, Run/Point, and Point-Only. The Locate mode can be activated at any time, even when another mode is set, by pressing the top orange button labeled Locate on the left side of the transmitter. To set the beeper unit to Run/Point and Point-Only mode, press the black Mode button. This button is located on the right side of the transmitter.

2702T&B

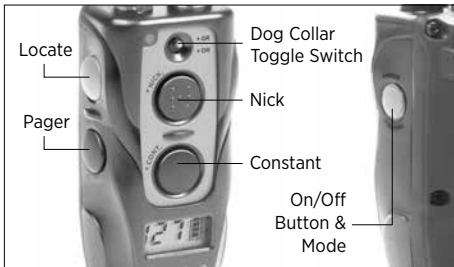

The two-dog model has a toggle switch on the face of the transmitter located above the Nick button. The toggle switch allows for selection of either receiver.



Set the toggle switch on the green position to select the green receiver and the orange position to select the orange receiver. The stimulation (Nick and Constant) along with the beeper and Locate modes will only operate when the toggle is in the desired position for the appropriate receiver.

3. Beeper Sound

When you press the Mode button the first time, the receiver will beep twice. The beeper unit will always start in Run/Point mode. The beeper will sound every 7 seconds while the dog is running, and every 2 seconds when the dog is on point or becomes stationary. The second time you press the Mode button, it will beep once and remain silent while the dog is running and beep every 2 seconds when the dog is on point or stationary.

To turn the beeper unit off, press the Mode button a third time. The unit will emit three rapid beeps, and the beeper will turn off. The Locate mode can still be used!

When the 2700T&B toggle switch is set on low pitch, the beeper will emit a double beep when it is in Run/Point mode or Point-Only mode. If the toggle switch is set on the high pitch, a single beep will sound when using Run/Point or Point-Only mode.

	Initial Beeper Sound	Mode	Action
Press 1st Time	2 Beeps	Run/Point Mode	- Dog running/moving: emits double beep every 7 seconds - Dog stationary/pointing: emits double beep every 2 seconds
Press 2nd Time	1 Beep	Point-Only Mode	- Dog running/moving: silent - Dog stationary/pointing: emits double beep every 2 seconds
Press 3rd Time	3 Beeps	No Beeper Mode	No sound

Note: The Locate button can be used in any mode you are in.

4. Beeper Volume Adjustment

The beeper volume level for the Run/Point mode and Point-Only mode can be increased or decreased by holding the Locate button down and briefly pressing the Pager button. The pitch of the beeper can be selected with a toggle switch located on the face of the transmitter. There are two beeper pitches: High (H1 = lowest volume, H2 = medium volume, and H3 = highest volume) and Low (L1 = lowest volume, L2 = medium volume, and L3 = highest volume).

	Toggle Switch High LCD Displays	Toggle Switch Low LCD Displays
Press Pager 1st Time (While holding down the Locate button)	H1	L1
Press Pager 2nd Time (While holding down the Locate button)	H2	L2
Press Pager 3rd Time (While holding down the Locate button)	H3	L3

Note: The Locate beeper volume is not adjustable; it is always on the highest level, L3 on low pitch, or H3 on high pitch.

5. Receiver Fitting

Proper Fit

The receiver should be fitted so that the medical grade stainless steel contact points press firmly against the dog's skin. You should be able to fit two fingers underneath the collar strap. The best location is on either side of the dog's windpipe.

Improper Fit

A loose fit can allow the receiver to move around on the dog's neck. When this happens, the contact points may rub against the skin and cause irritation. If the receiver is too loose, the contact will not be consistent and cause the corrections to be inconsistent. Dogtra uses medical grade stainless steel contact points and anti-microbial plastic to protect the dog's skin.

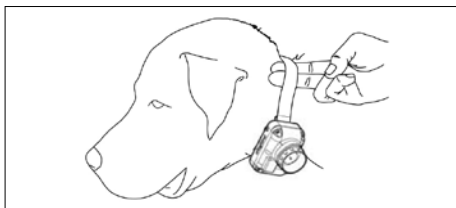

Attention!

Leaving the receiver in the same location on the dog's neck for an extended period of time can cause skin irritation due to the sensitivity from the contact points. If the dog is to wear the receiver for long periods, occasionally reposition the receiver every few hours so that the contact points are moved to a different location on the dog's neck and remove the receiver after 8 hours of usage. Make sure you check for skin irritation each time you use the unit.

6. Finding the Right Stimulation

The 2700T&B has a Rheostat Dial on the top of the transmitter (0 is the lowest and 127 is the highest). Remember that you will need to adjust the setting (upward or downward) depending on your dog's temperament and threshold for stimulation. Also, as the dog's attitude changes, especially during times of increased excitement or distraction, you may need to adjust the intensity level.

Note: The stimulation intensity can be adjusted even when the stimulation is in use.

7. Familiarizing the Dog to the Beeper

Turn the receiver on and leave it outside the dog's kennel area for about 30 minutes. Repeat this several times until you can see that the dog disregards the beeper. Next, adjust the beeper volume level to level L1, the lowest level. Fit the receiver on the dog and select the desired beeper volume level as the dog becomes accustomed to the beeping sound.

8. Maximizing the Distance

The 2700T&B has a range of 1 mile. Depending on the way you use your transmitter, the transmitter range may vary.

To get the greatest range, hold the transmitter away from your body and avoid touching the antenna. Keep your unit properly charged for maximum signal strength.

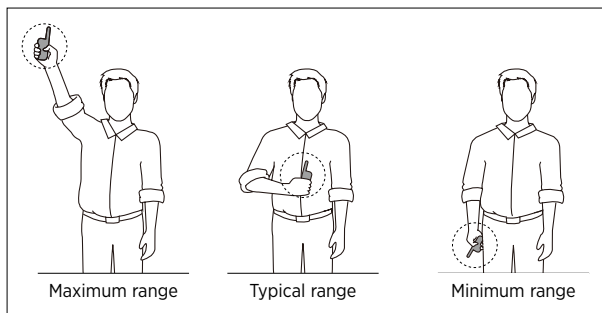

The range on the 2700T&B is reduced when the handheld transmitter's antenna is covered or in contact with your body. Refer to the following carrying methods for optimal range.

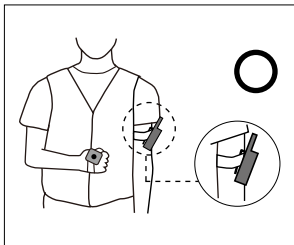
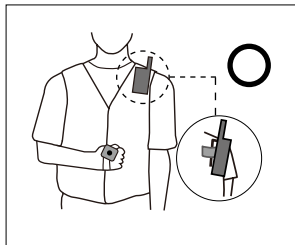

Carry the handheld transmitter with the antenna facing away from you.

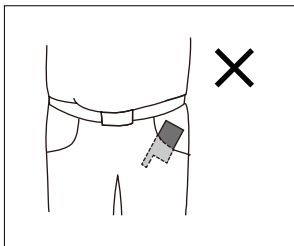
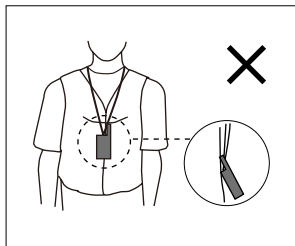

Do not place the handheld transmitter with the antenna touching your body or facing downwards.

9. LED Indicator

The LED indicator flashes every 4 seconds when the receiver is on and ready for use. The LED indicator will blink on both the transmitter and the receiver when the transmitter buttons are pressed.

The LED indicator color indicates the battery life level.

Green = Full charge

Amber = Medium charge

Red = Needs charge

If the unit is used while the LED indicator is red, it may shut down automatically.



Receiver Indicator Light

When the Constant button on the transmitter is pressed, the receiver indicator light will glow steadily (either green, amber, or red based on the remaining battery life), as long as you hold the button down, for up to 12 seconds. When the Nick button is pressed, the light comes on for a fraction of a second.

10. Charging the Battery

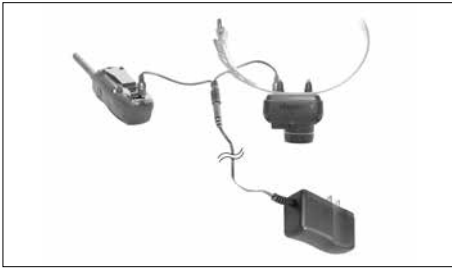

The Dogtra 2700T&B uses a lithium polymer battery. Recharge the unit if the indicator light is red or does not come on, the transmitter LCD shows only 1 bar on the indicator, or the system will not stay on when any button is pressed.

NOTE 1: Only use Dogtra-approved batteries, chargers, and accessories for your Dogtra e-collars. This will prevent any damage that can be incurred from attempting to use a different charger.

NOTE 2: The unit has a partial charge when it leaves the Dogtra facility. Upon receipt of the system, be sure to give it a full 2-hour initial charge before the first use away from any flammable substances.

NOTE 3: When a charger is not in use, disconnect it from the power source. Fully charge the batteries if the unit is to be stored without use for a period of 3 months or more.

Follow the steps below to charge your system:

1. Open the rubber plugs on the battery charging receptacles and plug in the charging cable.
2. Plug the charger into a 120-volt wall outlet or, if using the auto charger, plug into a cigarette lighter only for lithium polymer batteries (use a 220 volt European charger for Europe). All indicator lights should glow red when properly plugged in and the unit will automatically shut off during the charging process. You will need to turn the unit on again before use once the unit is fully charged and unplugged from the battery cable.
3. The lithium polymer battery is fully charged within 2 hours. The lights will stay red during the charging process and turn green once the unit is fully charged.
4. After charging, cover the battery charging receptacles with the rubber plugs.

11. Handheld Transmitter LCD



The LCD screen indicates the stimulation level on the screen ranging from (0-127). The battery life indicator shows:

3 bars = full charge

2 bars = medium charge

1 bar = needs charge

When pressing the Mode button, the selected beeper volume level is shown on the LCD (Note: Pressing the Mode button once will also set the unit in the Run/Point mode). When the toggle switch is set on low pitch the LCD will read: L1= lowest volume, L2 = medium volume and L3 = highest volume. When the toggle switch is set on high pitch, the LCD will read: H1 = lowest volume, H2 = medium volume and H3 = highest volume.

Care for LCD Transmitters in Cold Temperature

In cold temperatures (10°F or below), the Liquid Crystal Display (LCD) on your transmitter may be dim or slow to respond. Wait until the display becomes visible before selecting any training level. Even though the LCD screen might be dim or slow to respond when you push the

Nick or Constant button, the transmitter will still function properly. In the occurrence of extremely cold weather, the LCD screen might take a moment to respond causing the intensity level to freeze at that current level. In this situation, if you turn the Rheostat Dial, the level on the screen may not change but the actual intensity from the receiver will change in agreement with the dial.

In this situation, it is ideal to either wait until your transmitter is back to working order before emitting a correction, or while holding the Constant button down slowly turn the Rheostat Dial while watching your dog's reaction. Do not turn the Rheostat Dial rapidly, because the receiver will emit a static correction based on the level of the Rheostat Dial, which might not be correctly reflected on the LCD screen.

Attention!

When using the unit in cold temperatures, it is recommended that the transmitter is placed under your jacket next to your body. The warmth of your body will greatly improve the battery life and usage.

12. Attaching the Belt Clip

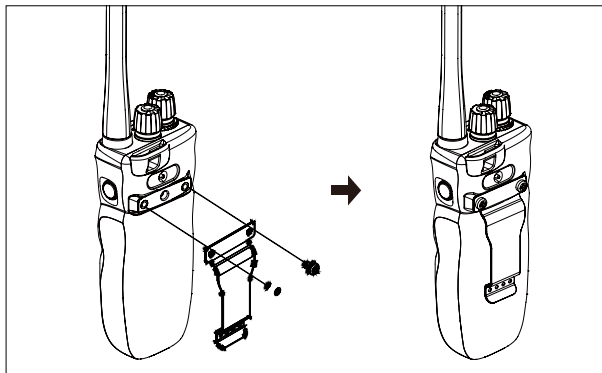

Follow the instructions below to attach the included belt clip to the transmitter.

1. Align the belt clip to the grooves on the back of the transmitter.
2. With a firm grip, screw on the belt clip's Phillips head screws with a screwdriver.

Caution!

Tighten until firmly in place. Be careful not to over tighten.

13. Using the Test Light



1. To turn on the receiver, place the red dot on the back of the transmitter to the red dot on the receiver. Hold the two red dots together for a moment until the LED light on the receiver comes on. The indicator light will come on for a moment then blink once every 4 seconds, showing that the receiver is ready to use (the receiver needs to be charged if the indicator light is red). The receiver will emit a melody when turned on.
2. Turn the transmitter on by pressing the black button on the right side of the transmitter until the LCD screen illuminates. The LED will blink every 4 seconds and the LCD screen will show the remaining battery life (the transmitter needs to be charged if there is only 1 bar showing on the battery icon for the LCD transmitter screen).
3. Place the test light, included in the package contents, on the contact points as shown in the diagram.
4. Watch the test light as you push the Nick button on the transmitter. It should light up for just a moment. The higher the intensity, the brighter the test light will be.

5. Watch the test light as you push the Constant button on the transmitter. It should light up as long as the button is pressed. However, as a safety feature, the receiver will automatically stop the stimulation if the Constant button is pressed for 12 seconds or longer.
6. Turn the Rheostat Dial on the transmitter clockwise and then counterclockwise. The test light should glow brighter with higher levels of stimulation and dimmer with lower levels. When you change the intensity dial, the number on the LCD screen will change as well.

Note: The test light may not be visible if the intensity level is set below level ten.

7. To make sure that your beeper is working properly, press the Locate button once with the horn portion facing away from you (or place your hand over the horn). The sound may be extremely loud and may cause discomfort to your ears. If you do hear an audible beeper sound, your Locate button is in working order.
8. Press the Mode button once; you should hear 2 rapid beeps. This will put you into the Run/Point mode. Keep the receiver steady to mimic your dog at a standstill point. Wait for a moment until you hear a double beep every 2 seconds. You may proceed to the next step if the double beep occurs.
9. Press the Mode button a second time; you should hear 1 rapid beep. This will put you into the Point-Only mode. Once again, keep your receiver steady and wait for a moment until the receiver emits a double beep every 2 seconds. If it is audible, move onto the next step.

10. Press the Mode button a third time; you should hear 3 rapid beeps. This mode will turn off your beeper and remain silent.

Note 1: The pitch that the beeper will emit will vary depending on your selection with the (high/low) toggle switch. The two-dog model: Dogtra 2702T&B has a fixed beeper pitch based on the color of the receiver. The pitch cannot be changed.

Note 2: When using the Run/Point mode or the Point-Only mode, the beeper volume level reverts back to the volume level that was last used.

Note 3: In the Run/Point or Point-Only mode the volume can be changed by holding down the Locate button and then pressing the Pager button when the high/low toggle switch is in the desired position. The unit must be turned on and in the Run/Point or Point-Only mode first.

Note 4: In the Run/Point or Point-Only mode, it is still possible to use electrical stimulation.

*** To make sure that your beeper volume is in working condition, please refer to page 17 for further testing instructions.**

GENERAL TRAINING TIPS

Getting Started With Your 2700T&B

Your dog must know some basic obedience commands before beginning training with the 2700T&B. A dog learns by first being shown a command, followed by lots of repetition over an extended period. As the dog becomes proficient at these commands, the trainer can introduce distractions and different locations to strengthen them.

Obedience Training on the Leash

Your dog must fully understand the obedience commands (sit, stay, here, heel, and kennel) before using the e-collar for reinforcement of these commands. A leash attached to a standard collar is used to "teach" the dog the basic obedience commands (here, heel, sit, and stay). A tug on the leash/collar is used to reinforce the command. When the dog complies with the command, use positive reinforcement/praise. Once the dog understands these commands, the e-collar can be used to reinforce them.

Beginning E-Collar Training

When you feel your dog understands the obedience commands on the leash we can now start with the e-collar training. With the dog on the leash and wearing the e-collar, continue with your obedience drills. Apply light stimulation (Nick or Constant) when a command is given; the stimulation can be removed as the dog complies. Through repetition, the dog learns to perform the command.

The final step is the avoidance phase in which the dog learns that he can avoid the stimulation altogether by performing your commands. When these training procedures are complete, the e-collar is used as a reminder when the dog does not comply with your commands at home or in the field. Keep your initial training sessions short and positive as dogs have a short attention span.

How Much Stimulation to Use

Always start with low levels of stimulation and work your way up depending on the disposition of your dog and the given situation. By using the correct amount of stimulation to get your point across, you will have a more controllable environment and a dog that is under less stress. Animals (and humans) perform better in a less stressful environment.

For more training information, please visit our website at www.dogtra.com.

MAINTENANCE

Basic Maintenance

Make sure the rubber charging cap is securely in place when the e-collar is in use. After each training session, carefully inspect the unit for any missing parts or damage to the casing. Damaged or broken casing may affect the waterproof guarantee on the unit. After confirming that there is no damage to the casing, rinse the receiver and clean out any dirt or debris.

Storage Maintenance

The 2700T&B should be fully charged before storing for extended periods. While in storage, the unit should be given a full charge once a month, and before the first use. Store the units in room temperature. Do not keep the units exposed to extreme climates.

Troubleshooting

If the unit is malfunctioning, please refer to the “Troubleshooting Guide” before sending it to Dogtra for service. If you have any questions or concerns, you may email them to info@dogtra.com, or call customer service at (888) 811-9111.

TROUBLESHOOTING GUIDE

1. My dog is not reacting to the system.

- Make sure the receiver and transmitter are on.
- Make sure the collar strap is tight enough so both contact points are touching the dog's skin.
- The contact points may be too short for the dog. To place an order for longer contact points that are more appropriate for your dog, please call (888) 811- 9111. If you are already using the longest contact points available, you might need to trim down the hair on the dog's neck so both contact points are touching the dog's skin.
- The intensity level may be too low for your dog. Keep increasing the stimulation until the dog responds, usually with neck movement, head shaking, looking over its shoulder, etc. (response may be very subtle).

2. The test light comes on, but I do not feel any stimulation.

- Testing the system at various levels using the test light is the best way to test your system. Your tolerance may be higher than the level you are testing yourself.
- The battery may be low, so check the LED light for battery life.
- If you have a full charge and you have done all of the above, your unit may need to be serviced. Please contact customer service at info@dogtra.com or (888) 811-9111.

3. The transmitter has no range or stimulation is less when the dog is farther away.

- The antenna(s) may be damaged. To order parts, please contact customer service at (888) 811- 9111 or go to www.dogtra.com.
- The range indicated on the unit's box is for flat terrain. Heavy brush, trees, hills, or moisture will affect the range of your unit. For best range, hold the transmitter vertically above your head, and/or try moving to higher ground.
- Any electrical conductors will affect the range, such as cars, chain-link dog runs, metal building, and radio towers. For best results, operate away from these structures.

4. My unit is not holding a charge.

- The batteries might not be charged properly, or the charger, splitter, and the charging port needs to be looked at. If you suspect your charger/splitter is not functioning properly please contact customer service at info@dogtra.com or (888) 811-9111. You can send in your charging units to have us inspect them.
- The charging pin may be damaged. Inside the charging port, there is a metal pin that should be standing straight up and stiff. If the pin is wobbling, broken, or missing, you will need to send the unit in to the Repair Department. The charging port must be clean prior to charging; clean the dirt out with a cotton swab and some rubbing alcohol. If the dog is in salt-water, be sure to rinse the receiver and charging port with clean water.

- For Dogtra units over two years old from the purchase date, the batteries may need to be replaced. You can replace them yourself by contacting Dogtra. But, damages incurred to the unit due to improper battery installation are not covered under any warranty and any other unauthorized servicing or tampering with the unit voids your limited lifetime warranty. This will be up to the user's discretion. If you are still having problems after replacing the batteries, Dogtra strongly recommends sending the unit in for inspection.

DOGTRA PRODUCT WARRANTY

LIMITED WARRANTY

For Dogtra Products Purchased from Dogtra Authorized Dealers

One-Year Warranty

Except as otherwise provided below, Dogtra warrants to the original retail purchaser (“You”) that its Dogtra products shall be free of defects in materials and workmanship for a period of one (1) year from the date of purchase (“Warranty”). The Warranty covers the cost of repair (parts and labor) or replacement (if repair is not feasible) of a defective Dogtra product during said one-year period. For such repaired or replaced products, the remaining portion of the original warranty period, or ninety (90) days, whichever is longer, shall apply. Dogtra, at its sole discretion, shall determine whether to repair or replace a product covered by the Warranty.

Warranty Conditions

The Warranty is not transferrable and applies to your Dogtra product only if:

- (1) You are the original retail purchaser of the product,
- (2) You bought the product from a Dogtra authorized dealer, and
- (3) You present a receipt or other proof of purchase showing a valid purchase date, the name and address of the authorized dealer, and the purchased product identified by model and/or serial number.

Warranty Exclusions

The Warranty does not cover damage, loss, or deterioration to your Dogtra product caused by misuse, neglect, abuse, or other improper handling of the product; by failure to follow use or care instructions; by use of the product for other than its intended purpose; by accident or natural forces such as fire or flooding; or by normal wear and tear such as scratches to the product surface.

The Warranty also does not cover Dogtra products that: are purchased from non-authorized dealers; are purchased outside of the United States or Canada; have been damaged during shipment (even if Dogtra paid or arranged for shipping); have been modified or tampered with in any manner; are opened or repaired by anyone other than Dogtra; or have serial numbers that have been altered or defaced.

Sole Warranty

This Warranty is the only warranty offered by Dogtra for its Dogtra products. Other than said Warranty, Dogtra makes no other representations or warranties whatsoever regarding its products, whether oral or in any product manual, on any packaging, on any website, or in any other written material. No dealer of Dogtra products, nor any employee or agent of Dogtra, is authorized to make any additions, changes, or extensions to the Warranty. Dogtra, at its sole discretion and at any time, reserves the right to modify the Warranty.

DISCLAIMER OF OTHER WARRANTIES

THE FOREGOING WARRANTY IS PROVIDED IN LIEU OF ALL OTHER WARRANTIES, WHETHER EXPRESS OR IMPLIED. DOGTRA DISCLAIMS ANY IMPLIED WARRANTIES INCLUDING, BUT NOT LIMITED TO, THE IMPLIED WARRANTIES OF MERCHANTABILITY AND FITNESS FOR A PARTICULAR PURPOSE.

Limitation of Remedies

Dogtra's liability is limited to the cost of repair or replacement of the Dogtra product under Warranty. Any claim or action to enforce the Warranty must be commenced within thirty (30) days of the Warranty's expiration for your product. Dogtra will not be liable for any indirect, incidental, special, consequential, or similar damages based on breach of warranty, breach of contract, negligence, strict tort, or any other legal theory related to Dogtra and its products. Damages that Dogtra will not be responsible for include, but are not limited to: loss of income or profits; loss of revenue or savings; loss of use of the product or associated products; cost of any substitute products or services; inconvenience, downtime, or any other time; loss of goodwill; claims of third parties including customers; and damage to property.

Legal Rights May Vary By State or Jurisdiction

The Warranty gives You specific legal rights, and You may also have other rights which vary by state or jurisdiction. Some states or jurisdictions do not allow certain limitations of implied warranties or of incidental or consequential damages or other remedies, so certain of the foregoing limitations may not apply to You.

If any portion of the Warranty is held by a court to be invalid or unenforceable, the remaining portions of the Warranty shall remain in full force and effect and shall in no way be affected or invalidated, and the invalid or unenforceable portion shall be modified so as to most nearly achieve the intent of the Warranty.

Product Registration

Dogtra recommends that customers register their products as soon as possible after purchase. Product registration will facilitate any future warranty service. You may also receive useful information and updates about your existing and future Dogtra products. To register your product, visit www.dogtra.com/product-registration. If your product is not registered with Dogtra, You will be required to provide a receipt or other proof purchase (as provided above) to qualify for warranty service.

How to Obtain Warranty Service

Should your Dogtra product require warranty service, please contact Customer Service by phone or email for a warranty evaluation (see below for contact information). Upon approval of your warranty work, Dogtra will repair or replace (at Dogtra's election) your product without charge for labor or parts. You are responsible for shipping, including cost, of your product to Dogtra for warranty service. Dogtra will handle shipping, including cost, of the repaired or replaced product back to customers in the USA. Dogtra will not be responsible for shipping, including cost and/or applicable taxes or fees, for products sent to Canada. Such costs, taxes, or fees will be borne by the customer.

To register your product, visit www.dogtra.com/product-registration.

Dogtra Customer Service

12322 Monarch Street, Garden Grove, CA 92841

(888) 811-9111

repair@dogtra.com

Mon – Fri, 8:00 AM to 4:30 PM (PST)

© 2021 Dogtra. All rights reserved.