

# REMOTE CONTROLLED DOG TRAINING COLLARS

OWNER'S MANUAL



## **Dogtra Company**

1250 E. 223rd Street, Suite 119  
Carson, CA 90745

Tel : (310) 522-1800

Fax : (310) 522-1805

Toll Free: 1-888-811-9111

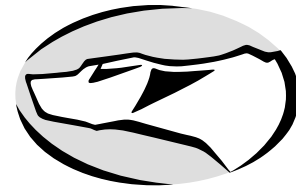

## ***dogtra 1700NCP SERIES***



---

## CONTENTS

• MAIN FEATURES .....	2
• PRODUCT SAFETY AND HEALTH STATEMENTS .....	4
• <b>dogtra</b> COLLAR PACKAGE CONTENTS .....	6
• DESCRIPTION OF TRANSMITTER PARTS .....	7
• DESCRIPTION OF COLLAR / RECEIVER PARTS .....	20
• BATTERY CHARGER .....	25
• CHARGING THE BATTERIES .....	26
• TESTING YOUR <b>dogtra 1700NCP SERIES</b> COLLAR .....	29
• OPERATING INSTRUCTIONS .....	31
• BELT CLIP ACCESSORY .....	35
• ACCESSORIES .....	37
• WARRANTY AND REPAIR .....	38
INFORMATION	

## MAIN FEATURES

- Easy-to-use, ergonomic transmitter.
- Rheostat dial that allows for gradual increases in stimulation intensity with no jumps between levels.
- The ***dogtra 1700NCP SERIES*** has a 1/2-mile range.
- Two-dog models allow the trainer to control two different dogs from one transmitter.
- Waterproof collar/receiver and transmitter.
- No external antenna on the collar receiver.
- Rechargeable, user-replaceable Ni-MH batteries.
- One-charger system allows the transmitter and receiver(s) to be charged at the same time.

- Over 3000 different identity codes to prevent conflicts with other e-collars.
- Easily visible blue LCD screen displays exact level of stimulation and can be seen in the dark.
- LED colored indicator to show remaining battery life.

## PRODUCT SAFETY AND HEALTH STATEMENTS

### Safety for your dog

Studies conducted by animal health professionals at Dogtra Company's training facilities showed no adverse effects to the cardiovascular or nervous system of dogs from e-collar stimulation. These studies involved healthy dogs in a controlled environment.

Dogs should be in good health during any e-collar training. Dogtra e-collars are not intended for use on dogs weighing less than 12 pounds or under 6 months of age.

Skin irritation can occur from prolonged wearing of the stainless steel contact points on the training collar. Most dogs will exhibit some type of irritation (pressure necrosis) from prolonged contact of stainless steel contact points. This is why it states in your owner's manual:

### Attention:

Avoid having the dog wear the collar with the contact points in the same place for more than two hours at a time. Leaving the contact points on the same spot for an extended period of time can cause skin irritation. If the dog is to wear the e-collar for long periods, occasionally reposition the collar so that the contact points are moved to a different spot on the dog's neck.

### Proper e-collar use

*dogtra* e-collars are intended for the sole purpose of behavior modification of dogs. They are not intended for human use or use on other animals. Dogtra Company does not assume any liability for improper use of the Dogtra e-collar.

### Aggressive dogs

*dogtra* does not recommend using the e-collar to correct dogs that are aggressive towards other dogs or people. In many such cases the dog will associate the stimulation with the other dog or individual and become even more aggressive. Dog aggression is best treated by a dog training specialist.

### Interference with other electronic devices

Dogtra's industry-leading technology filtering system ensures minimal interference with other electronic devices (cellular phones, security systems, etc.). Our digital microprocessor offers thousands of unique codes to eliminate frequency match-up with other Dogtra e-collars.

### Inadvertent activation

If the constant button is held down for 12 seconds or more the unit will automatically shut down. It will reactivate when the button is released.

## ***dogtra*** COLLAR PACKAGE CONTENTS

- Transmitter
- Receiver (two collar receivers for ***dogtra*** two-dog models)
- Battery charger and splitter cable
- Test light
- Owner's manual
- Carrying case

## DESCRIPTION OF TRANSMITTER PARTS

### ***dogtra*** 1700NCP (ONE-DOG)

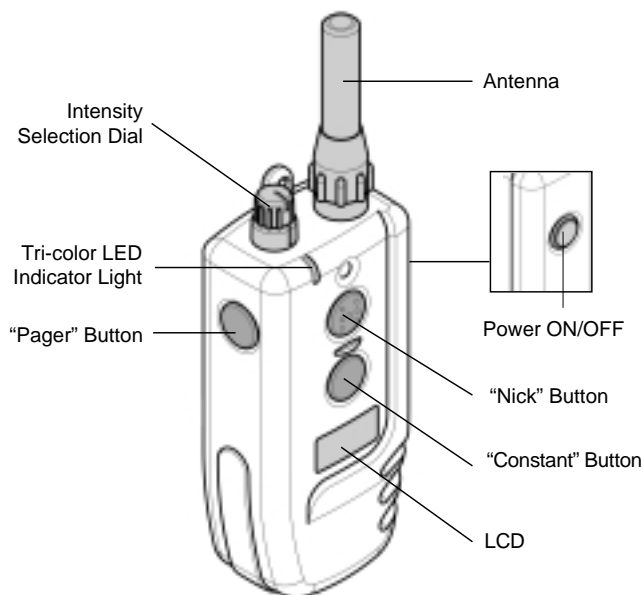

## DESCRIPTION OF TRANSMITTER PARTS

### *dogtrà 1702NCP (TWO-DOG)*

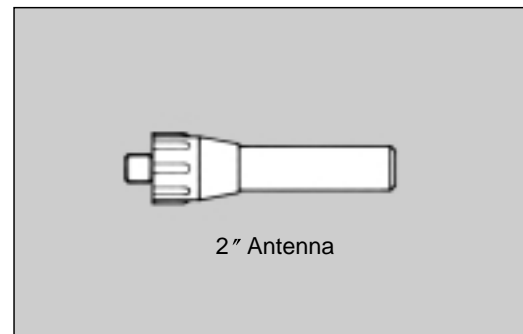
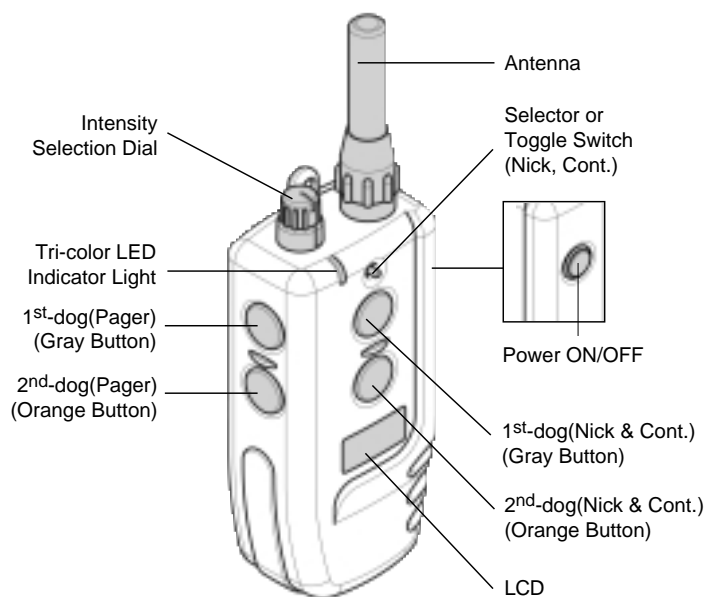

### Transmitter Antenna

A short 2" antenna is supplied with the *dogtrà 1700NCP SERIES* transmitter.

The antenna should be screwed into the top of the transmitter to ensure that the signals are sent properly to the collar receiver and that maximum range is attained.

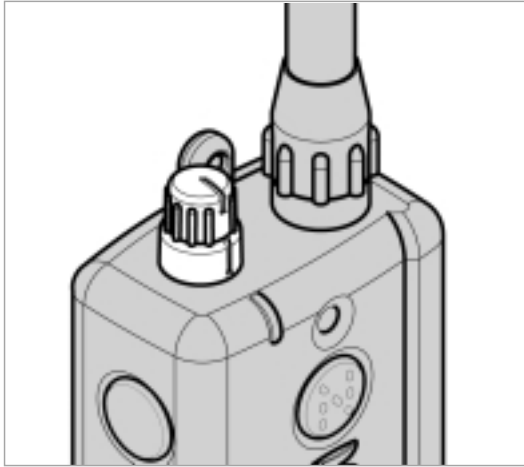

### Intensity Selection Dial

The intensity selection dial is located on the top of the transmitter: (0) being the lowest level and (127) being the highest. The LCD screen shows the intensity level during operation.

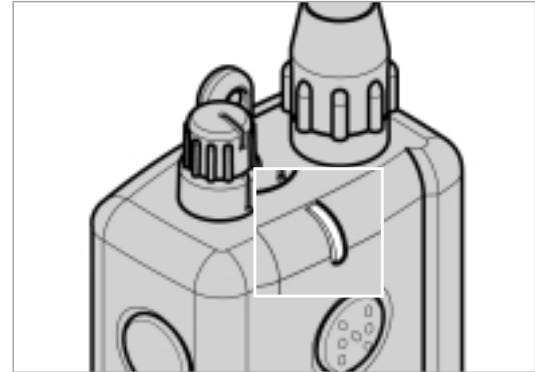

### Transmitter Indicator Light (LED window)

The transmitter indicator light is located near the intensity selection dial. It will flash every 2 seconds when the transmitter has been turned on. The color of the light indicates the status of battery life. It flashes green when the battery is fully charged and turns to amber when battery life is getting low. When the transmitter indicator emits a blinking red light, the battery needs to be recharged.

**green** = full charge, **amber** = medium charge  
**red** = needs charge



### **LCD (Liquid Crystal Display) Transmitter Screen**

The LCD panel indicates the stimulation level (0-127) on the screen. (P) appears when the Pager is pressed. The battery life indicator shows 3 bars at full charge, 2 bars at medium charge and 1 bar when it needs to be charge.

### **Care for LCD Transmitters in Cold Temperature**

In cold temperatures (10 degrees F or below), the liquid crystal display (LCD) on your transmitter may be dim or slow to respond. Wait until the display becomes visible before selecting any training level. Suggestion: Carry your remote close to your body as your body's warmth can improve operation and viewing of the LCD screen.

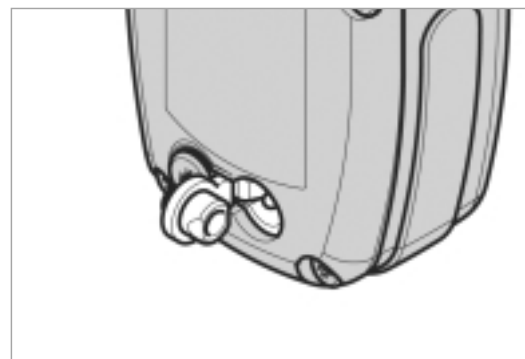

### **Transmitter Battery Charging Receptacle**

Located on the backside of the transmitter, the receptacle is covered by a rubber plug. Insert one end of the battery charging cable into the receptacle to charge the battery (See Battery Charging Procedure on page 28.)

After charging is completed, close the receptacle with its rubber plug to make sure dirt or water does not get inside.

## BUTTON FUNCTION

### *dogtra 1700NCP* ONE-DOG MODEL

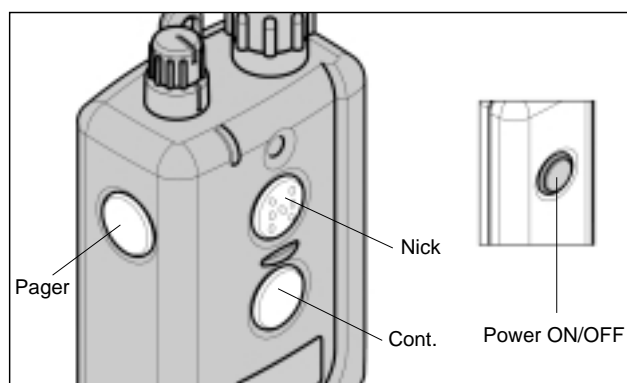

The transmitter for *dogtra 1700NCP* has four buttons (two on the face of the transmitter and one on each side).

### “Nick” Button

When the “Nick” button is pushed the receiver emits a single, rapid pulse of electrical stimulation.

### “Constant” Button

Pressing the “Constant” button gives continuous stimulation as long as the button is pushed, for up to twelve seconds. If the button is not released after twelve seconds, the stimulation will automatically turn off as a safety feature. The collar will be ready to be reactivated once the button has been released.

### “Pager” Button

Pressing the “Pager” button on the side of the transmitter causes the collar to vibrate. This is a great way of communicating with your dog using non-electrical stimulation.

**Transmitter Power ON/OFF**

The button on the right side of the transmitter is the ON/OFF button that activates the transmitter and display screen.

To turn the transmitter ON, press the “ON/OFF” button on the right side of the transmitter for two seconds. When the LCD light appears, the transmitter is ON. If there is no activity for 8 seconds, the transmitter will go into a standby mode and the display light will turn off. The display light will return when a button is pressed or the intensity dial is turned.

To turn the transmitter off, press the “ON/OFF” button on the right side of the transmitter. When the LCD screen displays “OFF” release the button.

**Battery Life Icon**

When the battery is fully charged, the LCD battery icon will show 3 bars and the color of the LED will be green. If the battery is partially discharged, the battery icon will show 2 bars and the color of the LED will turn to amber. When the battery icon reaches 1 bar it means the battery is low. The LED will blink red to indicate that the battery needs to be recharged.

**Display of the Stimulation Level**

The LCD screen indicates the intensity level (0 through 127) as the dial is turned.

## ***dogtrå* 1702NCP TWO-DOG MODELS**

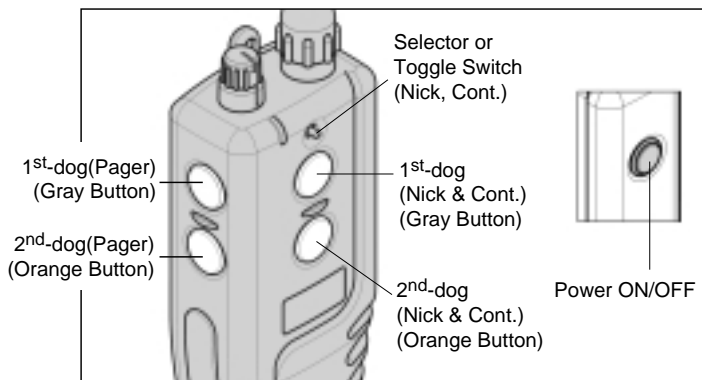

The transmitter for ***dogtrå* 1702NCP** has five buttons and a toggle switch.

The selector or toggle switch is used to switch between Nick and Constant stimulation modes.

The gray button corresponds to the receiver with the black collar strap and the orange button corresponds to the receiver with the orange collar strap. To switch between Nick and

Constant simply move the toggle switch to the appropriate mode.

On the left side, the top gray pager button corresponds to the receiver with the black collar and the bottom orange pager button corresponds to the receiver with the orange collar strap.

The ON/OFF button is located on the right side of the transmitter.

## DESCRIPTION OF COLLAR / RECEIVER PARTS

*dogtra 1700NCP SERIES* collar

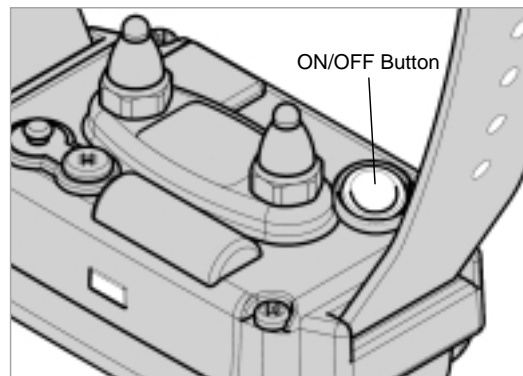
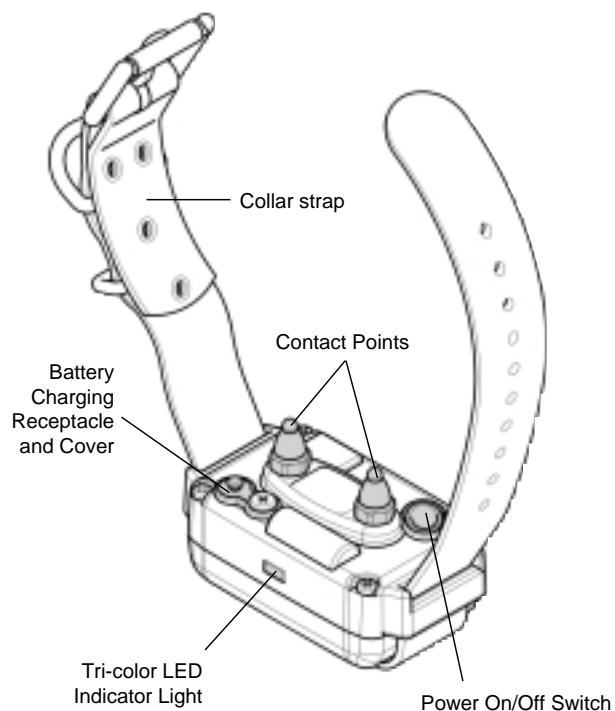

### Turning on the Collar Receiver

The ON/OFF button is on the bottom of the receivers. Push and hold the button for two seconds until the LED light, located on the front of the collar, starts blinking. The indicator light will blink once every 2 seconds after the color is turned on. The color of the light indicates the status of battery life. The LED glows green when the battery is fully charged and turns to amber when battery life is getting low. When the LED emits a blinking red light, the battery needs to be recharged.

**green** = full charge, **amber** = medium charge  
**red** = needs charge

When the “Constant” button on the transmitter is pushed, the collar indicator light will glow steadily as long as you hold the button down, for up to twelve seconds. When the “Nick” button is pushed, the light comes on for a fraction of a second.

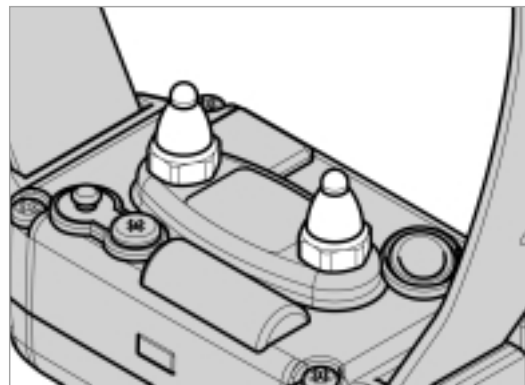

### **Fitting the Collar on the Dog**

The collar should be fitted so that the stainless steel contact points press firmly against the dog’s skin.

A loose fit can allow the collar to move around on the dog’s neck. When this happens the contact points may rub the skin and cause irritation. If the collar is too loose, electrical contact will be inconsistent and your corrections will be inconsistent also.

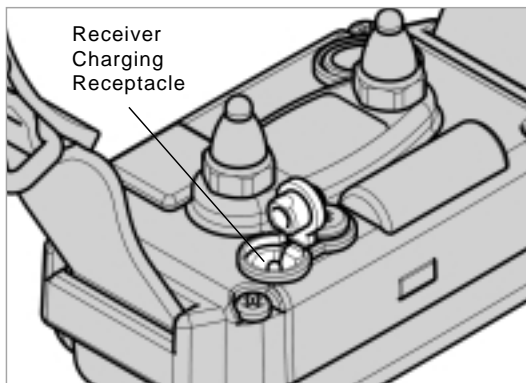

### Receiver Battery Charging Receptacle

On the inside of the collar receiver, next to the collar strap, is a battery charging receptacle with a rubber cover plug.

### Internal Antenna

The **dogtra 1700NCP SERIES** has a non-exposed antenna that is located inside the collar receiver.

## BATTERY CHARGER

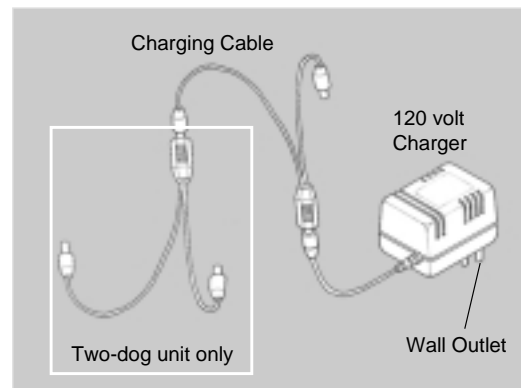

The battery charger and charging cables allow you to charge both the transmitter and receiver at the same time. The battery charger is designed for a 120 volt wall outlet. (European 230-volt AC chargers and 12-volt field charger for your automobile are also available.)

To use the battery charger for the two-dog unit, combine both sets of battery charging cables as shown. This enables you to charge the transmitter and both receivers at the same time.

## CHARGING THE BATTERIES

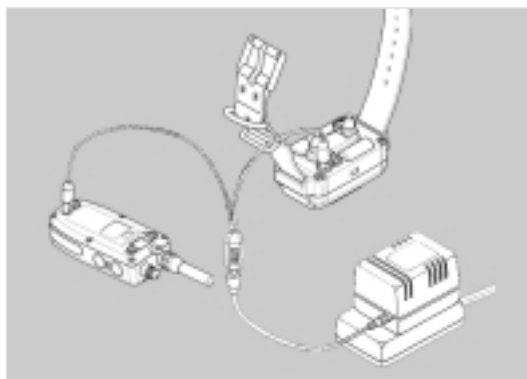

**dogtra** uses Ni-MH (Nickel-Metal-Hydride) batteries that do not set a memory and can be charged on a regular basis without harm to the battery. There is no need to completely drain the batteries between charges. However, doing so will help to extend the overall lifetime of the batteries.

1. Charge the batteries for 14 hours before using the collar for the first time.

2. Do not charge the batteries near any flammable substances.
3. Fully charge the batteries for 14 hours if the collar is to be stored without use for a period of a month or more.
4. Recharge the battery if :
  - the indicator light on the collar is emitting a red color
  - the indicator light on the transmitter or receiver will not come on
  - the indicator light on the transmitter or receiver comes on momentarily but will not stay on when the “Constant” button is pushed.

### Battery Charging Procedure

1. Attach the charging cables to both the transmitter and receiver(s), as shown on page 26.
2. Plug the charger into a 120-volt wall outlet or, if using the accessory field charger, plug into a cigarette lighter. (Use a 230-volt European charger for Europe.) When properly plugged in, all indicator lights should glow red.

The receiver automatically turns off when you insert the charging cable into the battery-charging receptacle on the receiver.

3. After charging, cover the battery charging receptacles with the rubber plugs on the transmitter and receiver.
4. The battery is fully charged with a 14-hour charge. The lights will stay red during the charging process. They DO NOT turn green when fully charged. Charging the batteries for more than 14 hours at one time will not extend battery life.

### TESTING YOUR *dogtra* 1700NCP SERIES COLLAR

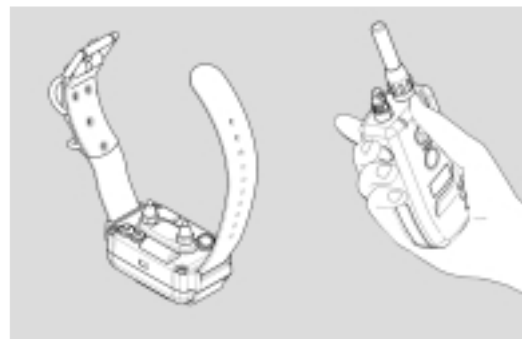

1. Turn the collar/receiver on by pressing the ON/OFF button on the receiver. The indicator light will come on for a moment then blink once every two seconds, showing that the collar is ready to use. (If the indicator light is red, or if there is only 1 bar showing on the battery icon on the LCD transmitter screen, the unit needs to be charged.)
2. Turn the transmitter on by pressing the button on the right side of the transmitter. The LCD screen shows the amount of battery life remaining and the LED blinks

once every two seconds. (If the color of the LED is red, the battery should be charged. Also, if the LCD battery icon shows 1 bar or nothing, your unit should be charged.)

3. Watch the test light as you push the “Nick” button on the transmitter. It should light for just a moment.
4. Watch the test light as you push the “Constant” button on the transmitter. As a safety feature, the collar receiver will automatically shut off stimulation if the constant button is depressed for twelve seconds or longer.
5. Change the intensity dial on the transmitter clockwise and then counterclockwise. The test light should glow brighter with higher levels of stimulation and dimmer with lower levels. When you change the intensity dial, the number on the LCD screen will change as well.

**NOTE : It is normal for the test light not to come on if the intensity level is set below level ten.**

6. Pressing the “Pager” button on the side of the transmitter causes the collar to vibrate for up to twelve seconds. The collar will reactivate when you push the button again.

## OPERATING INSTRUCTIONS

### Fitting the Collar

The collar strap should be adjusted so that the contact points are held firmly against the dog’s skin. If the collar is too loose, irritation may result from the contact points rubbing against the skin.

If the dog has a heavy coat, move the receiver up and down to work the contact points down into the coat.

### ATTENTION!

**Avoid having the dog wear the collar with the contact points in the same place for more than two hours at a time. Leaving the points on the same spot for extended periods of time can cause skin irritation. If the dog is to wear the e-collar for long periods, occasionally reposition the collar so that the contact points are moved to a different spot on the dog’s neck.**

### **Intensity Selection**

To select the intensity level, start on the zero (0) setting. Gradually increase the level until you get a response from the dog that would be equivalent to a quick pull or jerk with a leash.

Remember that you will need to adjust the setting (upward or downward) as the dog's attitude changes, especially during times of increased excitement or distraction.

Prolonged use of the Pager (12 seconds or longer) will drain the batteries more quickly.

### **Maintenance**

The receiver and collar strap should be cleaned periodically with detergent and water to prevent malfunction.

Always clean and rinse the collar thoroughly with tap water after use in salt water. Be sure the charging receptacle is completely dry before inserting the battery charger into the transmitter or receiver.

## Reception

The **dogtra 1700NCP SERIES** collar has a half-mile range. Depending on the way you use your transmitter, the transmitting range may vary. Hold the transmitter away from your body and avoid touching the antenna to get the greatest range.

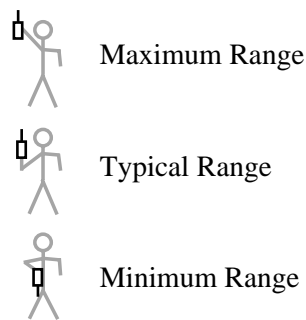

If your finger touches the antenna near the dial on the top of the transmitter, the actual range may be reduced. Additional environmental factors may also affect the range of your unit.

## BELT CLIP ACCESSORY

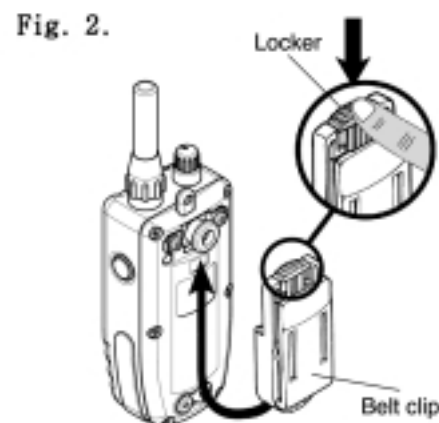
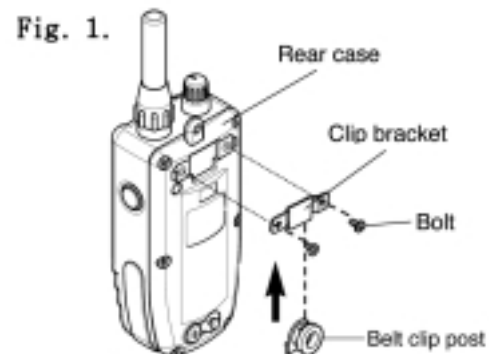

## BELT CLIP ACCESSORY

- 1) Remove the clip bracket from the rear case.  
Fig.1.
- 2) Insert the belt clip post into the clip bracket  
(upward as shown) and then re-tighten the  
bolts. Fig.1.
- 3) Attach the belt clip onto the belt clip post.  
Fig.2
- 4) When you separate the transmitter from the  
belt clip, pull upward on the transmitter  
while pushing downward on the locker.  
Fig.2

## ACCESSORIES

The following items may be purchased  
separately :

### **European Charger**

Designed for use with 230V AC electrical  
outlets in Europe.

### **Field Auto Charger**

Designed for use with the 12-volt cigarette  
lighter in your car.

## WARRANTY AND REPAIR INFORMATION

**Dogtra Company** provides the original purchaser a **LIMITED LIFETIME WARRANTY** for the 1700NCP SERIES on parts (excluding batteries) from the date of the original purchase. Labor is covered for two years after purchase. Once the labor warranty has expired, all repairs will incur a variable labor charge depending on the extent of work required.

### **To Qualify for the Limited Lifetime Warranty:**

The limited lifetime warranty applies to units purchased after Dec. 31, 2005. Fill out the warranty registration card that came with your Dogtra unit and mail it in along with a copy of your receipt within 30 days of purchase. Or, you can register your product online at [www.dogtra.com](http://www.dogtra.com).

### **Not Covered Under Warranty:**

If product registration is not completed within 30 days of purchase and/or the product is resold, the warranty will become void and all repairs will be subject to applicable labor fees.

**Dogtra** DOES NOT replace defective units or provide refunds after 30 days from date of purchase.

**Dogtra's** warranty DOES NOT cover repairs or replacement due to misuse, improper maintenance or lost units. Any water damage on models that are not waterproof will not be covered. All replacement costs for either the transmitter or receiver is the owner's responsibility.

The Limited Lifetime Warranty will expire (5) years from the date a unit is discontinued in production by Dogtra Company.

\* Batteries, or the labor to replace them, are NOT covered under the warranty after the first year.

The warranty is void if the unit has been altered or an unauthorized person has attempted repair work.

**Procedure for Repair Work:**

Return shipping for warranty work is the owner's responsibility. The cost for shipping (via regular ground service) back to the customer is covered by Dogtra Co. within the continental United States. Any expedited shipping service will be at the owner's expense. Dogtra is not responsible for loss of training time or inconvenience while the unit is in our warehouse for repair work. Dogtra does not provide loaner units or any form of compensation during the repair period.

A copy of the sales receipt showing purchase date is required before warranty work is begun.

Write a note briefly explaining the problem and include your name, address, city/state/zip code, daytime phone number and evening phone

number. Or, you can visit our web site at [www.dogtra.com](http://www.dogtra.com) to fill out a Service Request Form. If repair costs are not covered under warranty, we will call you for credit card information once the work has been completed. For any questions concerning your Dogtra products call us Toll Free at 1-888-811-9111, Pacific Time.

Send repair units to:

**Dogtra Company**

1250 E. 223rd Street, Suite 119  
Carson, CA 90745

MEMO

---

MEMO

---

---

42

---

43

MEMO

---